

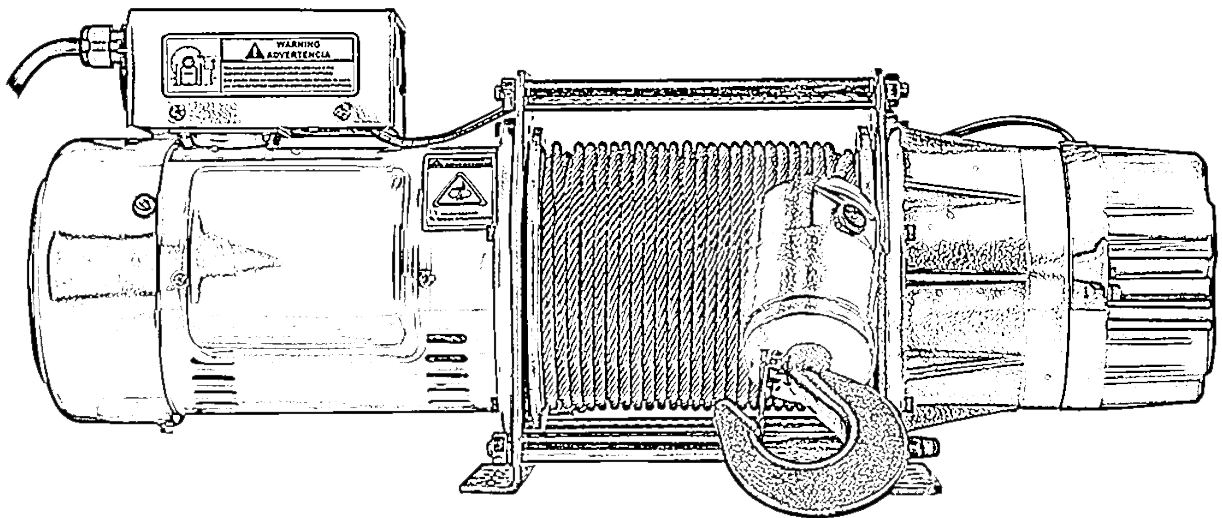

PWG / PWK Winches Series

User's Manual / Manual de usuario
Safety Warnings / Advertencias de Seguridad





PWK380



PWG450i



PWG600

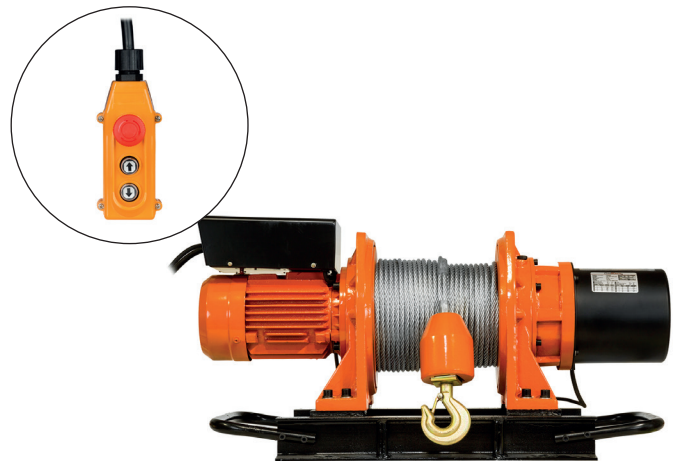

PWK625i



PWK1250i



PWG1750

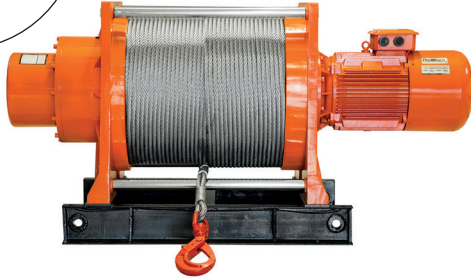

PWK12600i

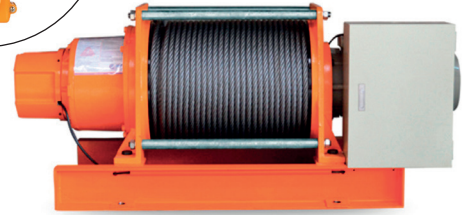

PWG7700i

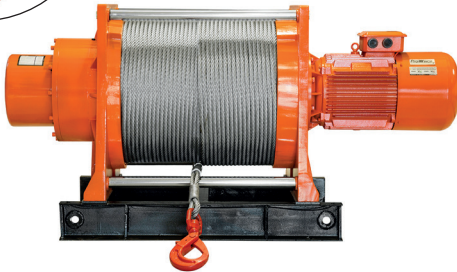

PWK21000i



PWK21000iXL



**PWK2900i &
PWK4300i**



PWG23700i

PROPERTY REGISTRY N° 189487
ANY REPRODUCTION IS FORBIDDEN
PROPERTY OF PROWINCH® 2022 - V.06.23 [LA] ALL RIGHTS RESERVED
PROWINCH LLC COMPANY WITH QUALITY MANAGEMENT SYSTEM

PROWINCH® DISCLAIMER

Prowinch® LLC declares that it has made all safety recommendations related to the purchased product to the customer. As a result, it does not assume any responsibility for any damages or losses that the client or third parties may suffer. These can be caused by or as a direct or indirect result of a breach or omission of instructions or safety warnings in the User Manual and Security Warnings provided with the unit purchased. Prowinch® LLC will not be liable for accidents and/or damages to persons and/or property resulting from the negligent use of the product. In no case does Prowinch® LLC assume any liability arising from using these voluntary recommendations and does not offer any guarantee concerning them. These recommendations do not take precedence over the current safety regulations of the plant. For purposes of enforcing the warranty of the product purchased, Prowinch® LLC, will only be liable for any damage when proven the user has followed each one of the warnings contained in the User Manual and Safety.

1. It is the sole responsibility of the Client / User to verify that the acquired equipment, products, and accessories comply with the characteristics, capacities, requirements, components, accessories, and other conditions for the use that the Client/user intends to give it.

2. It is also the sole responsibility of the Client / User to ensure that the equipment and products purchased are operated and maintained with adequate safety standards and by personnel properly trained in their use. The Client / User is also responsible for implementing all security measures necessary to prevent accidents or damages to people or property and for following the indications and warnings of the corresponding manual.

3. Any assistance provided by Prowinch® LLC in selecting the equipment, capacities, and characteristics required by the client is delivered free of charge and based on the information about the application, use, and requirements provided by the client. It is not the responsibility of Prowinch® LLC to verify the accuracy of the given information. It is the sole and exclusive responsibility of the client -or who will use the equipment and products acquired- to ensure that the specifications comply with the capabilities, characteristics, up-to-date maintenance, and everything necessary for a correct and safe operation about the intended use.

4. Prowinch® LLC recommends using winches with four brakes for personnel lifting. The use of winches with three brakes or less, or operating with safety standards less than required for personnel lifting is not recommended.

5. To guarantee the safety of the equipment's operators, it is necessary to conduct inspections and maintenance of the equipment according to the recommended frequency of its work cycle. It is mandatory to keep records and evidence, including written and photographic reports of: Maintenance, Start-up, Load Tests, Training, Certifications, Inspections, and Reports of failures and accidents.

6. The reports mentioned above must be emailed to registros@prowinch.com within the first seven calendar days after an event.

7. Compliance with timely implementation of mandatory activities described in points 6 and 7, in addition to all the activities mentioned in the corresponding guidelines, are the user's sole responsibility. Failure to comply with the preceding conditions releases Prowinch® LLC from any liability. The information contained in this manual may contain technical errors or inaccuracies. Prowinch® LLC is not responsible for errors, omissions, or incorrect information. This manual is subject to change without prior notice. Download the latest version available at www.prowinch.com. Always check www.prowinch.com for the latest information regarding this product.

8. This manual is subject to change without prior notice. Download the latest version available at www.prowinch.com.

9. Always check www.prowinch.com for the latest information regarding this product.

**WARNING**

Hoists, Cranes and other Lifting and material-movement related equipment USERS, must be knowledgeable about the safe and proper use of this equipment and be aware of their responsibilities as outlined in all applicable standards and regulations.

The ASME/ANSI B30 Standard contains provisions that apply to the construction, installation, operation, inspection, testing, maintenance, and use of cranes and other lifting and material-movement related equipment.

As OSHA's, ASME and ANSI standards state, the installation, setup and operation of these units and equipment shall be performed by a qualified person.

OSHA requires rated load tests for new and altered cranes, OSHA's standard at 29 CFR 1910.179(k) states:

Operational tests.

Prior to initial use all new and altered cranes shall be tested to insure compliance with this section including the following functions:

Hoisting and lowering.

Trolley travel.

Bridge travel.

Limit switches, locking and safety devices.

The trip setting of hoist limit switches shall be determined by tests with an empty hook traveling in increasing speeds up to the maximum speed. The actuating mechanism of the limit switch shall be located so that it will trip the switch, under all conditions, in sufficient time to prevent contact of the hook or hook block with any part of the trolley.

Rated load test. Test loads shall not be more than 125 percent of the rated load unless otherwise recommended by the manufacturer.

Once a rated load test is performed, paragraph 1910.179(k)(2) requires that "[t]he test reports shall be placed on file where readily available to appointed personnel."

In order to ensure Safety and installation requirements Prowinch requires Load Tests to be performed prior to initial use for all Hoists, Winches and Cranes, as well as other related components. Not fulfilling this requirement is dangerous, could lead to equipment failure and will automatically void the warranty.

The B30 Standard is intended to:

(a) Prevent or minimize injury to workers, and otherwise provide for the protection of life, limb, and property by prescribing safety requirements.

(b) Provide direction to manufacturers, owners, employers, users, and others concerned with, or responsible for, its application.

**WARNING**

(c) Guide governments and other regulatory bodies in the development, promulgation, and enforcement of appropriate safety directives.

The equipment covered by the B30 Standard is subject to hazards that cannot be abated by mechanical means, but only by the exercise of intelligence, care, and common sense. It is therefore essential to have personnel involved in the use and operation of equipment who are competent, careful, physically and mentally qualified, and trained in the proper operation of the equipment and the handling of loads. Serious hazards include, but are not limited to, improper or inadequate maintenance, overloading, dropping or slipping of the load, obstructing the free passage of the load, and using equipment for a purpose for which it was not intended or designed.

Failure to Read, Understand and Follow the information in the corresponding ASME B30 Standard for your Hoist and Lifting equipment may result in severe INJURY or DEATH. It is YOUR RESPONSIBILITY to consider all risk factors and follow all the equipment related ASME B30 standard, which comprises the following volumes:

B30.1 Jacks, Industrial Rollers, Air Casters, and Hydraulic Gentries.

B30.2 Overhead and Gantry Cranes (Top Running Bridge, Single or Multiple Girder, Top Running Trolley Hoist).

B30.3 Tower Cranes.

B30.4 Portal and Pedestal Cranes.

B30.5 Mobile and Locomotive Cranes.

B30.6 Derricks.

B30.7 Winches.

B30.8 Floating Cranes and Floating Derricks.

B30.9 Slings.

B30.10 Hooks.

B30.11 Monorails and Underhung Cranes.

B30.12 Handling Loads Suspended From Rotorcraft.

B30.13 Storage/Retrieval (S/R) Machines and Associated Equipment.

B30.14 Side Boom Tractors.

B30.15 Mobile Hydraulic Cranes.

B30.16 Overhead Hoists (Underhung).

B30.17 Overhead and Gantry Cranes (Top Running Bridge, Single Girder, Underhung Hoist).

B30.18 Stacker Cranes (Top or Under Running Bridge, Multiple Girder With Top or Under Running Trolley Hoist).

B30.19 Cableways.

B30.20 Below-the-Hook Lifting Devices.

B30.21 Lever Hoists.

B30.22 Articulating Boom Cranes.

B30.23 Personnel Lifting Systems.

B30.24 Container Cranes.

B30.25 Scrap and Material Handlers.



WARNING

B30.26 Rigging Hardware.
 B30.27 Material Placement Systems.
 B30.28 Balance Lifting Units.
 B30.29 Self-Erecting Tower Cranes.
 B30.30 Ropes.

DO NOT



WARNING

1. DO NOT Operate, install, or repair the hoist unless trained and authorized.
2. DO NOT Operate the hoist unless you have first read the operator's manual.
3. DO NOT Operate the hoist without appropriate PPE and without performing a pre-shift inspection.
4. DO NOT Operate the hoist if not complying with all required OSHA regulations.
5. DO NOT Lift more than the rated load.
6. DO NOT Lift people or lift loads over people.
7. DO NOT Wrap the hoisting rope or chain around the load.
8. DO NOT Operate with the chain/rope not properly seated in the sprockets, drum, or sheave.
9. DO NOT Operate unless the direction of the hook travel agrees with the direction shown on the control.
10. DO NOT Operate the hoist unless the hook travel limit devices function properly. (Test without a load PRE-SHIFT)
11. DO NOT Operate the hoist with twisted, kinked, damaged, dirty, or unlubricated chain or rope.
12. DO NOT Operate a damaged or malfunctioning hoist.
13. DO NOT Operate the hoist when the hook is not centered under the hoist
14. DO NOT Remove or obscure this tag or other WARNING & SAFETY LABELS.

DAILY CHECKLIST



WARNING

TAGGED HOIST: Ensure the crane or hoist is not tagged out of order.

CONTROL DEVICES: Test Run. Ensure all motions agree with control device marking.

BRAKES: Check all motions for excessive drift and abnormal stopping distances.

HOOK: Check for damage, cracks, nicks, gouges, deformations on throat opening, wear on saddle or load-bearing point, and twist.

HOOK LATCH: Check for proper operations.

**WARNING**

WIRE ROPE: Check for broken wires, broken strands, kinks, and deformation or damage to the rope structure.

CHAIN: Check for corrosion, wear, elongation, twist, nicks, or gouges. Keep Chain/Wire Rope Clean and Lubricated.

REEVING: Check the rope for proper reeving and that rope parts are not twisted.

LIMIT SWITCHES: Ensure that all limit devices stop lifting motion before the load block or chain/rope stop strikes the hoist.

OIL LEAKAGE: Check for any signs of oil leakage on the crane/hoist and the floor.

UNUSUAL SOUNDS: Check for unusual sounds from the hoist while operating.

WARNING & SAFETY LABELS: Ensure that labels are not missing and they are legible.

DISCLAIMER	4
SAFETY BULLETIN	5
SAFETY PRECAUTIONS	11
Safety precautions.....	11
Handling precautions.....	13
General environmental precautions.....	18
SPECIFICATIONS	44
Structural Characteristics	19
Training and certification.....	23
Maintenance.....	23
Main technical data.....	24
Service factor	24
General method for cable sizing.....	24
Safety use.....	25
Installation and testing.....	25
Common trouble and solutions.....	26
Wiring diagram.....	27
Troubleshooting and possible solutions.....	28
Warranty.....	29
PWK3801	30
PWK3801.....	30-32
PWG450i	33
PWK450i	33-35
PWG600	36
PWK600	36-38
PWK625i	39
PWK625i	39-41
PWK1250i	42
PWK1250i	42-44
PWK1750	45
PWK1750	45-47
PWK2900i	48
PWK2900i	48-50
PWK4300i	51
PWK4300i	51-53
PWG7700	54
PWK7700	54-56
PWK12600	57
PWK12600	57-59
PWK21000	60
PWK21000	60-62
PWK21000XL	63
PWK21000XL.....	63-65
PWK23700	66
PWK23700.....	66-69

www.prowinch.com

Thank you for purchasing a Prowinch® winch. This manual describes the operation and maintenance of the winch. All information in this publication is based on the newest production information is available at print time.

1. SAFETY PRECAUTIONS

Prowinch's winches are designed to deliver a safe and trustworthy service if they are operated according to this manual. This manual contains essential information to help you properly install, operate and maintain your winch for maximum performance, economy, and safety. Please study its contents thoroughly before putting your winch into operation. You will experience long, dependable, and safe service by practicing correct operating procedures and following the recommended preventive maintenance suggestions. After thoroughly familiarizing yourself with the contents of this manual, we recommend that you carefully file it for future reference.

Applications for PWG and PWK Prowinch®'s winches

1. Mining: Lifting, conveyors, maintenance, loading platforms, counterweights, drilling.
2. Construction: Concrete plants, hydroelectric plants, lifting materials, lift towers, equipment, machinery.
3. Industrial: Warehouses, factories, conveyors.
4. Marine: Fishing industry, boats.
5. PWG450i and PWG600: Specially designed for construction applications such as windows and delicate material lifting, lift towers and any load lifting during constructions projects.

Mandatory use of:



Hard Hat



Safety Glasses



Safety Gloves



Safety Shoes

1.1. Safety Precautions



WARNING:

This symbol indicates unsafe practices or situations which may cause damage to the property and even injuries to the personnel.



DANGER:

This symbol indicates a potentially dangerous situation which if not avoided may cause severe injuries or death



DANGER

All operators and other users who are near the steel chain or its load must wear required safety equipment: gloves, safety helmet / hard hat, safety shoes and eye protection.



WARNING

Before installing, removing, inspecting, or performing any maintenance on the winche, the unit must be unplugged, locked out, and tagged out. Do not use this equipment in hazardous locations.

⚠ WARNING

Crush hazard
⚠ ADVERTENCIA
Peligro de atrapamiento

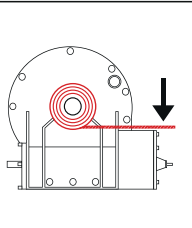
ProWinCH

	⚠ WARNING
	This winch must be mounted with the wire rope in the under wind direction.
	⚠ ADVERTENCIA
	Este winche debe ser montado con la salida del cable de acero por debajo del tambor.

ProWinCH

⚠ WARNING
Verify torque, tighten bases periodically
⚠ ADVERTENCIA
Verificar torque, apriete bases periódicamente

ProWinCH

Read and understand the contents of this User Manual thoroughly before handling the product. Practicing correct and safe operating procedures and carrying out the recommended preventative maintenance will ensure a long, reliable, and safe service.

After carefully reading and understanding the User Manual, store it for future reference.

HANDLING PRECAUTIONS

- Keep the winch in optimal working condition. Failure to adequately align, support, or attach winch to a suitable mounting base could result in a loss of efficiency or premature failure of winch, wire rope, or mounting base.
- Do not use any chain or cable that was not specifically designed for the unit you are using.
- To avoid an electrical discharge, make sure that your equipment is adequately grounded, by certified personnel.
- Make sure the winch works properly without load, before applying loads
- Do not lift weight with the edge of the hook.
- Do not perform lifting with more than one winch at once.
- Never exceed the maximum weight lifting capacity.
- Disconnect the equipment from the power supply in order to avoid any involuntary use.
- Do not use pulleys or accessories that are not approved for this winch.

WEAR APPROPRIATE PROTECTIVE CLOTHING

- Do not use loose clothing or any jewelry when operating this equipment.
- You must wear protective leather gloves when handling the winch rope.
- You must wear non-slip safety footwear and a safety helmet.
- Long hair must be tied back to operate this equipment.
- You must wear appropriate safety glasses to operate this equipment.

KEEP A SAFE DISTANCE

- Always stand clear, keep hands clear, keep others away at least 1.5 times the length of the winch rope. Wire rope can break without warning.
- Never touch the rope or hook while they are under tension or under load. Even at rest, the winch may have the rope in tension. Never guide a rope under tension onto the drum with your hands.

POWER CORD MISUSE

- Do not lift the winch or any equipment from the power cord.
- Never route electrical cables across sharp edges.
- Never route electrical cables near parts that get hot.
- Never route electrical cables through or near moving parts.
- Never route electrical cables over battery terminals.
- Always insulate and protect all exposed wiring and electrical terminals.



DANGER:

Failure to observe these instructions could lead to serious injury or death.

DO NOT OVERWORK THE EQUIPMENT

- If the motor overheats, stop all operations, and let the winch cool down. Check for any damage before restarting any operation.
- If the winch stops during operation, stop and thoroughly check for any damage before restarting operation.
- Do not exceed maximum rated capacity.

CHECK FOR DAMAGED PARTS

- Before using this equipment, check for any visual damage in the motor or wire rope.

WINCH REPAIR

- In order to repair a Prowinch® winch, use only original Prowinch® parts. Using unauthorized parts will void warranty.

WINDING THE WINCH CABLE

- You must wear leather gloves to handle the winch rope. To proceed properly you must apply and maintain a small load on the rope. While the operator winds the rope, a second person should lead to the correct location. Start as far as possible, keeping it centered.
- Do not let the winch rope fall off or slip and always keep a safe distance from the winch. Repeat this process until one (1) meter of cable has been left unwound.
- Disconnect the remote or/and from the power source.
- The last five wraps of wire rope must be left on the drum to assist the wire rope clamp in holding the load.



When using IWRC wire, wear leather gloves to eliminate or reduce the possibility of cuts caused by broken strands. Inspect the cable and equipment frequently. The cable must be replaced immediately if there are signs of wear, kinks, rust, broken strands, or any other signs of deterioration. Prowinch® and its distributors are trained and awarded certificates of training in the use and maintenance of the entire product line.



PROWINCH LLC® has no direct control over the use of this equipment and its operation. In accordance with good practice and safety is the responsibility of the owner, the operator and operational staff to follow these rules.



ASME B30.7-2011 has been used as a guide to prepare this list of what should and should not be done. All personnel must be properly trained and accredited for the use of this equipment.



DANGER:

Improper operation of the system can potentially create a situation dangerous, if not avoided, it could result in death or serious injury. To avoid a potentially hazardous situation, the operator

- 1.** Do not operate the winch until you have read and understood all these rules and the equipment manual delivered by PROWINCH LLC[®], including instructions and maintenance manuals.
- 2.** Do not operate a damaged equipment, that functions incorrectly.
- 3.** Do not operate a equipment that has been modified without previous PROWINCH[®] approval.
- 4.** Do not exceed the max. rated load.
- 5.** Do not use this equipment with cable damage: twists, bends, rust, broken strands or worn.
- 6.** Do not use any extensions or modifications to the equipment.
- 7.** Do not release the load when the equipment is loaded.
- 8.** Do not use this equipment to lift people except for those equipments that meet the standard ASME B30.7- 2011 in facilities that comply with the ASME B30.23-2005 or are approved by SERNAGEOMIN.
- 9.** Do not lift loads over people and make sure that all personnel remain a safe distance from the supported load.
- 10.** Do not try to extend or repair the cable.
- 11.** Protect the loading cable from welding spatters or other harmful contaminants.
- 12.** Do not operate the winch if there is any object or friction element or improperly deviating the cable.
- 13.** Do not apply the load to the tip of the hook or to the hook latch.
- 14.** Do not use equipment with an accessory, pulley, sling, shackle or any additional element that is not in proper condition and meets the specifications required for loading the maneuver.
- 15.** Do not operate beyond the limits of travel.
- 16.** Do not leave any load being lifted by the equipment without taking specific precautions
- 17.** Do not use the load cable as a ground for welding.
- 18.** Do not allow the cable or hook to be touched by a welding electrode.
- 19.** Do not lose or hide these Safety Handling Precautions.
- 20.** Do not operate any equipment that has not been installed and anchored to meet the required calculations and regulations.
- 21.** Do not lift loads that are not in balance.
- 22.** Do not lift loads that are not balanced and that the holding action is not secure, always keeping the corresponding slack.
- 23.** Report any malfunction or irregular operation of the equipment.
- 24.** Do not operate any equipment on which the safety placards or decals are missing or illegible.
- 25.** Do not operate the equipment without safety wear: safety footwear, protective gloves, safety helmet, safety glasses and any additional required element.
- 26.** Unplug the power cord if the equipment is not being used
- 27.** Electrical connection must have a circuit breaker that allows de-energize the equipment. This should be within reach of the operator.
- 28.** Do not operate the equipment without engine and moving parts protection.

**WARNING**

An improper operation of the equipment can create a potentially hazardous situation which, if not avoided, could result in minor or moderate injuries. To avoid a potentially hazardous situation, the operator must be a qualified professional.

1. You must install the equipment leveled on a firm foundation and sure to be in a secure position.
2. You must check brake operation, stressing the equipment before every lifting operation.
3. You must use hook latches. Latches are to retain slings, chains, etc. in loading operations.
4. You must ensure that the hook latches are closed and not supporting any loads.
5. Load should be free to move without obstruction.
6. You must avoid swinging the load or hook.
7. Inspect equipment regularly, replace damaged or worn parts, and keep appropriate records of maintenance.
8. Only use PROWINCH® recommended parts to repair this equipment
9. You must use only cables which are in good condition and according to the recommendations manufacturer.
10. Do not reach to the equipment cable's limit, always leave five (5) turns of cable inside the drum.
11. Do not distract your attention from the operation of the equipment.
12. Do not allow the equipment to be subjected to sharp contact with other equipment, structures, or objects through misuse.
13. Do not adjust or repair the winch unless you are qualified to perform such adjustments or repairs

**DANGER:**

Be sure to disconnect the power supply once the operation is completed. Never leave powered equipment without operator supervision.

**DANGER:**

The use of these units is exclusively stationary, any external force can exceed the rated capacity and damage the equipment.

HANDLING PRECAUTIONS

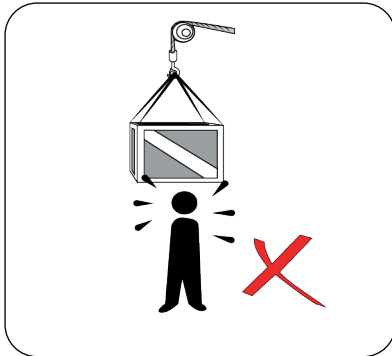

1. Do not exceed rated load. Make sure you know and the ability to lift maximum capacity of your equipment.

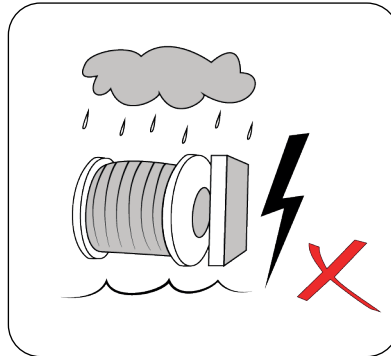

2. Frequently inspect the hoist's steel chain. In case of any damage, replace it.

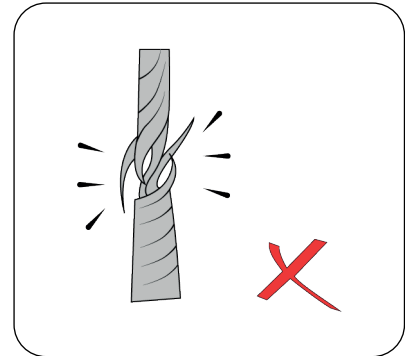

3. Check frequently the hoist's steel chain. In case of any damage, replace it.

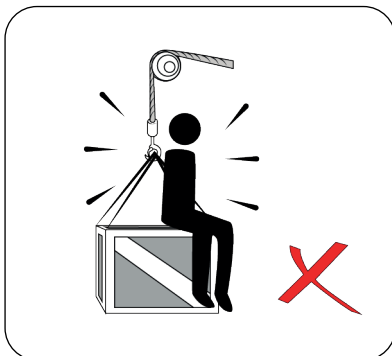

4. Do not use the equipment to lift or move people.

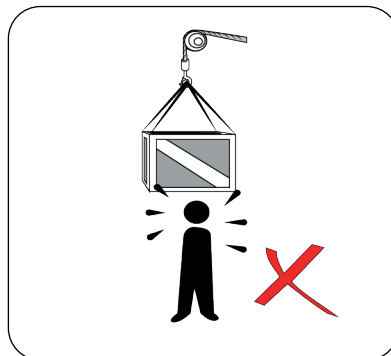

5. Do not stand under the load. Load could fall and potentially cause death.

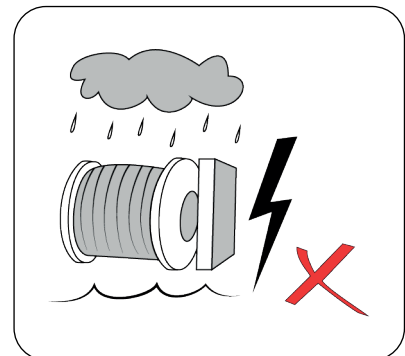

6. Do not use the hoist under the rain. Protect the engine and switch from wet weather.

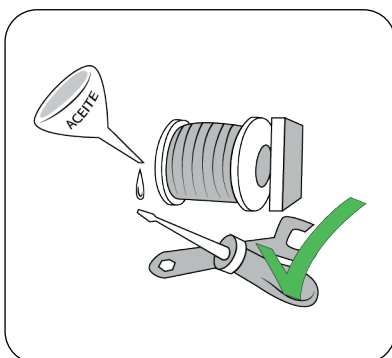

7. Perform frequent inspections and maintenance at least once a year.

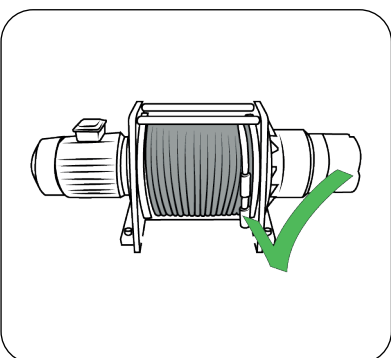

8. Always verify installation before operating.

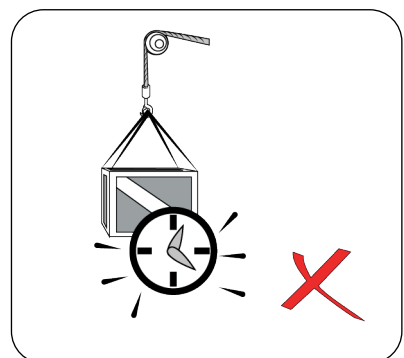

9. A heavy object must not stay up in the air for an extended period of time, it may cause girder deformation and/or cause an accident.

GENERAL ENVIRONMENTAL PRECAUTIONS



DANGER:

The following environmental conditions can cause malfunction of the winch.

The following environmental conditions may cause malfunctions in the equipment. When operated outdoor, a shelter should be used for extreme weather conditions: below 14 degrees F or above 104 degrees F.

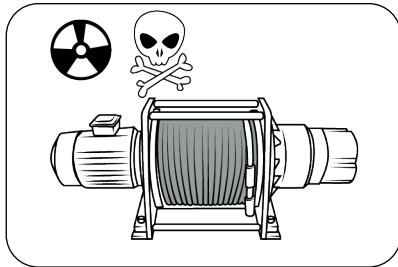
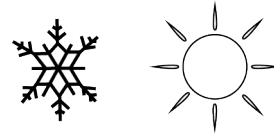

If used near chemicals, corrosive gas or explosives may cause an explosion. Exposure to salt or acids may cause malfunctioning.

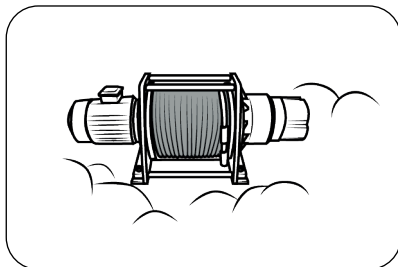

Exposure to sand may cause malfunctioning.

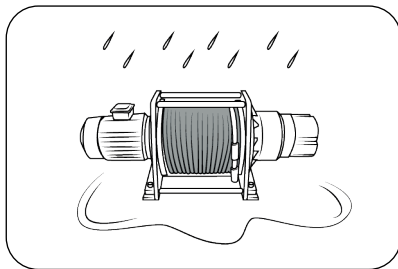

Avoid exposure to rain or snow. It may cause rusting of the equipment.

WARNINGS



STRUCTURAL CHARACTERISTICS

This product works with single-phase or three-phase motor with planetary transmission NGW, using a hook and steel cable. The brake is disc with electromagnetic release.

1. **Control button:** "Dead man" type pushbuttons.
2. **Motor:** It adopts a single-phase or three-phase, isolated motor with high starting energy and low inertia.
3. **Transmission structure:** Adopts NGW planetary mode gear for reduction. Adopts advanced steels that have a heat treatment, with a long shelf life.
4. **Electromagnetic brake application:** Adopts electromagnetic brake device. In case of losing electrical power, it brakes automatically mechanically, never backs up, is safe and reliable.
5. **The steel cable and drum:** The steel cable is installed on the drum. Fixed with safety bolt can guarantee preventing the wire rope from coming loose; you can easily change the wire rope or adjust its direction.

Steel Cable anchoring system to the drum

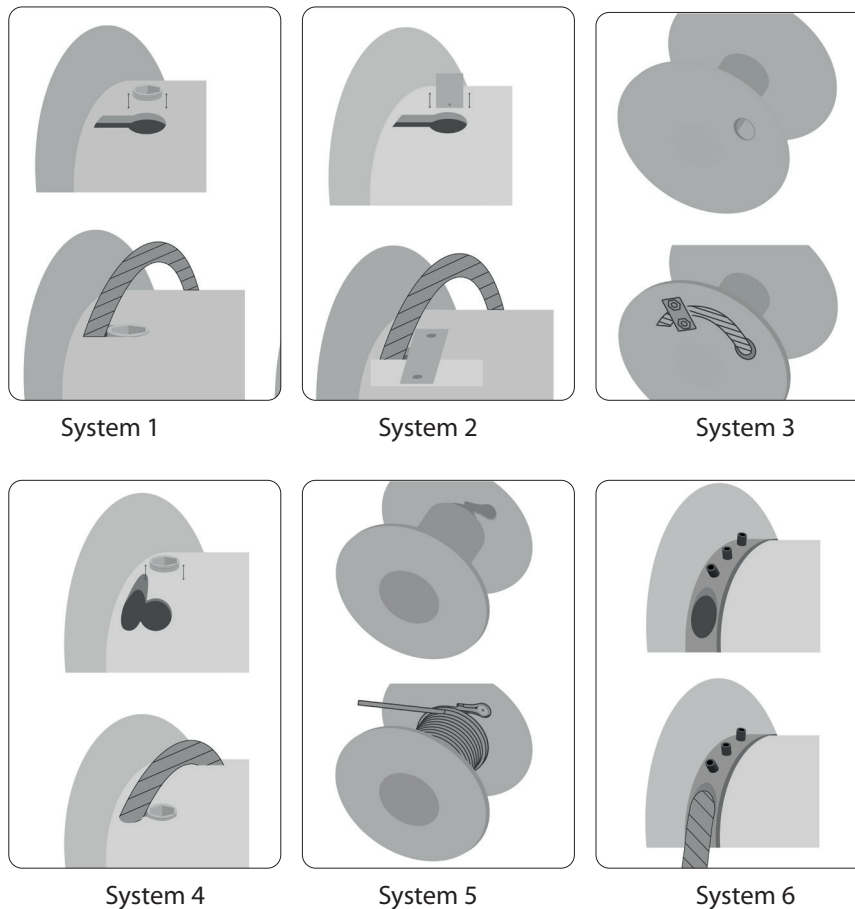

Proper procedure to correctly apply the rope

By holding the right hand or left hand with the index finger extended, palm up or palm down, the proper procedure for applying left and right lay rope can easily be determined.

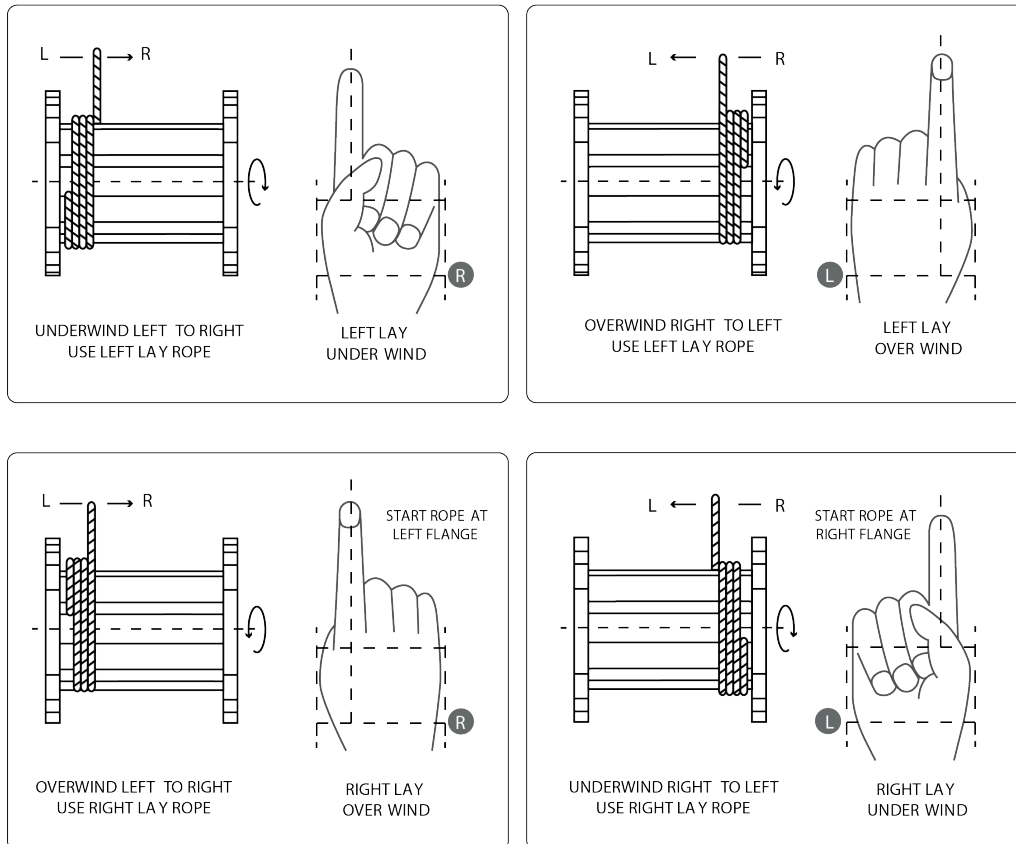

INSTALLATION AND TESTING PROCEDURE

- The supporting structure the winch is mounted to, must be designed by an engineer, to withstand the loads and forces by the winch for the rated load.
- Install in location that allows the operator to move and stay clear of the load.
- Locate pendant controls at a convenient level above the operating floor.
- Do not install where the load hook can be lowered beyond rated hook travel under normal operating conditions.
- Check that power supply meets the requirements of the equipment to be installed. If the power supply does not meet therequirements stipulated in the nameplate of the equipment can cause damage to electrical parts and winch motor. The voltage should be +/-5% fo the specified value.
- If the circuit of the electrical connection is correct, the operating direction of the winch should be as the control switch. Otherwise check that the phases are not reversed.

Testing

- Check operating mechanisms for proper operation, proper adjustment, and unusual sounds such as, but not limited to, binding noise of the wire rope and bearing squeal.
- Check winch upper limit device without a load on the hook at the beginning of each shift.
- **Unload testing:** Operate several times, there can't be vibration and/or unusual sound.
- **Loaded testing:** Pull rated load several times, checking drum's rotation, electric connections; there can't be vibration and / or unusual sound.
- **Braking system:** Braking system must automatically stop and hold up to the rated load if the operating controls are released and in the event of complete power failure. Braking systems must limit the speed of load during lowering, with or without power, to prevent uncontrolled or fast lowering.
- **Hook inspections:** Check hooks for distortion (bending, twisting or increased throat opening; wear, cracks; damaged or malfunctioning latch)
- **Winch Rope Inspection:** Visual inspection daily for excessive wear and/or distortion.

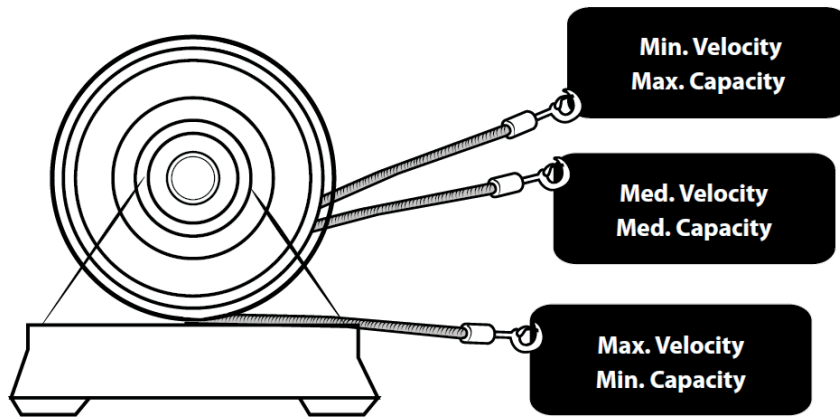

Load calculation

Pulley coefficient
 P - Rope tension
 T - Pulley coefficient
 W -Load

LOAD CALCULATION				
PULLEY NUMBER	1	2	3	4
BEARING PULLEY	0,98	1,96	2,94	3,92
BUSHING PULLEY	0,92	1,92	2,88	3,84

Trolley capacity to pull load: Rolling resistance can be caused by the degree of the angle, the type of track and the condition of the car.

Necessary conditions to use

1. Pull evenly using only a wire rope.
2. Depending on the incline, the maximum capacity to tow is up to 10 times the lifting capacity indicated on the equipment, which includes the weight of the car.
3. The steel cart must have wheels with wheel control precise.
4. The car track cannot have an error greater than 2 degrees lateral deviation.

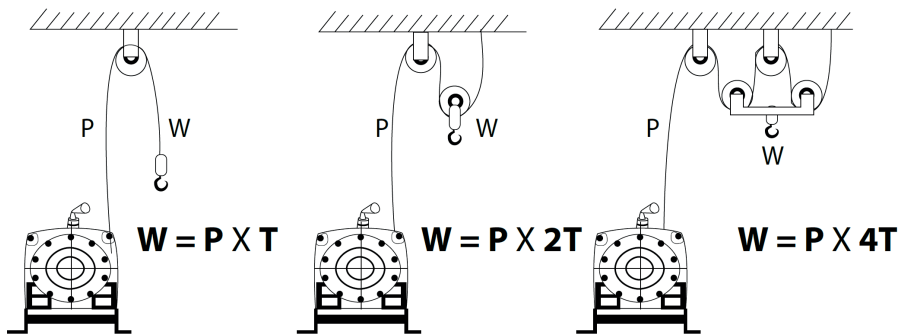

b. Calculation of work angle

To obtain a uniform winding of the steel cable, the working angle must not exceed 1.5 degrees.

In the case of units with a fixed deflecting pulley, it is necessary to multiply the drum width by 16. The result is the minimum

distance for the location of the deflecting pulley (in the case it is fixed).

Example: A drum 11 centimeters wide ($11 \text{ cm} \times 16 = 176 \text{ cm}$) can work at a minimum distance of 1.76 meters.

In the image we see the Drum (A) and the pulley, sprocket or roller.

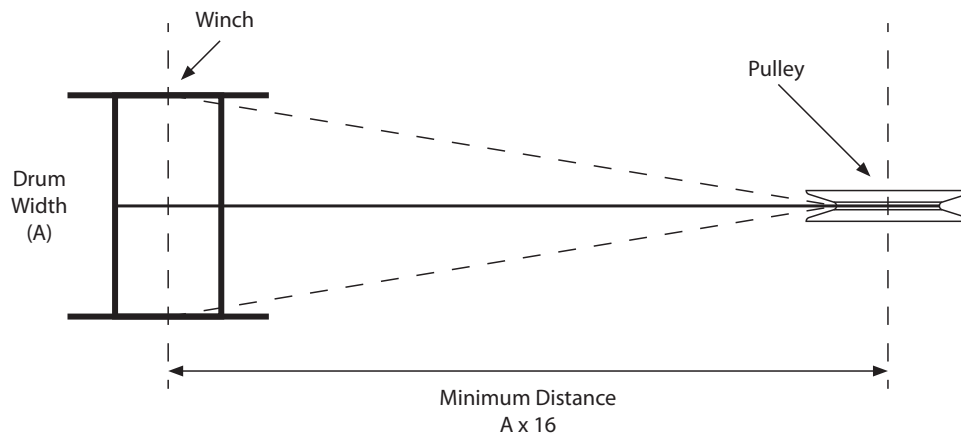

WARNING

All electrical installation must consider the peak or maximum consumption at Start.

Note: Verify curve of the Circuit Breaker .



TRAINING AND CERTIFICATION MAINTENANCE

To contribute to the safety of all users, workers, employees, employers, owners, and all those involved in the operation and use of winches, Prowinch® provides training for the use and maintenance of winches applied to different types of applications. On the understanding that safety has to do with special equipment and the whole chain of processes involved in the installation, operation, maintenance, and use of such equipment. For this purpose, we have developed manuals for installing, using, and maintaining winches and lifting personnel platforms. They contain essential references and indications necessary to understand, consider or check for safe and proper use of winches that, together with their parts and accessories, can safely meet the expected life cycle and work. These manuals were created considering our experience and based on the main indications of ASME B30.7 and ASME B30.23 Personnel Lifting Systems. Prowinch® has acquired the rights and received the necessary authorizations and licenses by the American Society of Mechanical Engineers ASME to translate and reproduce these standards, with the ASME's written consent, to apply them in our instruction manuals in several controlled and copyright corresponding copies.



WARNING

The owner assumes responsibility to install the unit by qualified professional. All structural calculations must be done by a Certified Structural Engineer. An improper installation will lead to accidents that could harm or cause death to users or people near work site. An improper installation and incorrect electrical connection will terminate the warranty. Any intervention to this unit without Prowinch®'s approval will terminate the warranty.

MAINTENANCE

The equipment has a planetary gear for maximum mechanical efficiency. Verify your equipment is well lubricated. Apply grease in the grease fitting every three months (only for models with that fitting). Keep lubricated steel cable, if it is oxidized or is corroded by rain water or weather, please remove the entire cable and apply the recommended lubricant . If corrosion has affected the cable, replace it. The electric winch must be inspected and frequently used. It should be fully inspected every six months.



It is your responsibility to periodically check the condition of the steel cable, anchor or any parts that can be worn loose or damaged in both the unit and the object to move.

MAIN TECHNICAL DATA

MODEL	KDJ-3200E1	KDJ-3200E1	KDJ-3500E1
NORMAL Rated load	2200	3200	3500
Speed (m/min)	7 - 12.5	7 - 12.5	7 - 12.5
Lift (m)	97	97	140
Rated power(kW)	6	7.5	9
Voltage (v)	Three phase 380VAC		
Frequency (Hz)	50Hz		
Electric current (A)	12	15.4	18.2
Diameter of the 16 18 18 cable wire (mm)	16	18	18
Capacity of cable (m)	100	100	143
N.W. (kg)	473	508	573
Work System	S3-40% 60min		

SERVICE FACTOR

SERVICE	LOAD	TIME	MAINTENANCE
NORMAL	<65%	<25%	6 ~ 12
HEAVY	>65%	>25%	3 ~ 6
SEVERE	<100%	Duty cliche limit	1 ~ 3

GENERAL METHOD FOR CABLE SIZING

1. Power cable specification affects the lifetime and performance of the electric winch and motor. It is very important to read the contents on the following chart carefully before use. You can not use a power cord that is lower than those in the chart below.

Three-phase 380V/480V	1100W	2200W	3000W	4000W	5500W	7500W
Speed (m/min Diameter (mm ²))	2.5	2.5	4	4	5.5	8

2. Power cable must not exceed 50 meters of length, if exceeded , use a larger diameter cable to ensure proper operation.

3. To construction applications, use power cable with low section cores, for great flexibility and improved safety.

4. Connect the power cable directly into the power supply , ensuring all connection with the respective fasteners.

5. Each line connection cable must be secured in place using bolts to prevent sparks, high temperatures, over-heating, etc. This can decrease life service of this equipment.

6. The power cable line must be fixed from one end. If the power cable comes loose the voltage would drop, which would influence seriously on this equipment performance.

7. To ensure the safety, the green wire must be properly grounded.

SAFETY USE

1. To install and use this equipment should consider safety as the first principle.
2. This equipment must be operated by a qualified worker with knowledge in Industrial safety.
3. When the machine is in use, the staff can not use the framework hook , lifting platform for other work or remain under the equipment or load.
4. Do not repair or modify this equipment without authorization of Prowinch . Replacement parts and service must be performed in Prowinch.
 - Whether the switch is flexible, the control switch coincides with the operation of the equipment, lifting and lowering the load, and can be stopped at any time.
 - Whether there are unusual noises while operating.
 - Whether the wire or/and chain has any visual damage. If there is damage, please stop the operation and change it immediately to guarantee safety.
 - Never operate winch with less than three (3) wraps of rope around the drum. Rope could come loose from the drum, as the rope attachment to the drum is not designed to hold a load.
 - Whether the fastener of every position of machine becomes flexible.
5. This equipment must be operated with empty load before using each time, to check the following actions- Please use according to this instructions and recommendations. Also follow the recommendations for voltage and rate load. Never exceed equipment or rope rated capacity.
6. Always wear heavy leather gloves when handling winch rope.
7. Never use winch as a hoist or to suspend a load.
8. Do not apply the load to the tip of the hook or to the hook latch.
9. Do not keep hanging loaded objects for long periods of time.
10. Do not use the equipment to lift or move people.
11. While changing the steel wire rope, must pay attention to the head of steel wire rope.
12. Attention: the motor work system of this electric winch is S3-25% 20min (one duty cycle is 20 minutes, work for five minutes, let the equipment rest for 15 minutes).

INSTALLATION AND TESTING

1. Installation Attachments and anchorages of this equipment must provide a balanced mounting and be capable of withstanding loads imposed by the equipment under operating conditions. The installer or/and owner are responsible for completing all structural tests to ensure proper installation. Prowinch® is not responsible for improper installations.
2. Testing
 - Whether the working voltage of testing installation site accords with the demand stipulated on the data plate of the products, lest makes the machine burn out because the power sends mistake, its voltage should be range in specified value $\pm 10\%$.

- Whether the circuit of the electric apparatus connection reliable, the direction of the rising and dropping should according to the direction of the switch.
- Unload testing ---- There cannot be any vibration and/or unusual sound during hoisting or lowering.
- The load is testing ---Go up and down rated load for several times, check machinery its rotate, electric attachment and connection normal and reliable. e. When the rated load drops, applies the brake hang in the air , its gliding amount should not exceed 1 of the length of the steel wire rope involved in for less than one minute1.5%

Maintenance of Winch

1. This machine adopts a planet gear to control the speed during the power down and transfer. Please make sure the gear is properly lubricated at all times. It is recommended operator place grease inside the filler hole every three months.
2. If any rust or corrosion appears on the steel wire rope, you must remove the entire steel wire rope, apply lubricating grease and keep it well maintained.
3. The electric winch should be followed and used the frequent degree. Overhaul in an all-round way through certain time, should generally go on once every year.

COMMON TROUBLE AND SOLUTIONS

Common trouble	Main reason	Solutions
Hands press the lifting switch, The motor can't rotate.	1.The power has not put through. 2. Wiring is break or take off loose. 3. The switch don't work.	1. Put through the power. 2.Check the wiring and repair. 3. Repair or adjust the switch.
The gliding amount is too big after cutting out.	1. The automatic spring is out of shape. 2. Grit slice wearing and tearing.	1. Change the automatic spring. 2. Check or change the gear
The noise unusually increases.	1. It is bad to lubricate. 2. The gear and bearing damaged after using for a long time. 3. Fasten position to loose and take off. one fasten or not	1. Put more lubricating grease. 2. Check or change the gear and bearing 3 Check whether the assemble.
Electric leakage.	1.Do not work in earth or have no earth. Interior wi ring touches the shell.	1. Check earth or connect the earth. 2. Check or remove the interior wiring.
Hands press the lifting switch big noise with motor, the spark of the switch is too big, can't lift the height article.	1. The voltage of the power is on the low side. 2. The input cable section is too long too thin, the voltage lower too much. 3. The interval is too narrow between grits slice and apply the brake block. 4. The coil of apply the bake burn out.	1. Check the voltage of the power. 2. Check whether the cable section meet the requirements 3. Change the girt slice or adjust the interval, keep 0.35-0.45mm. 4. Change the coil of the apply the brake.

WIRING DIAGRAM

Daily	Quarterly	Monthly	Annual	Part	Normal Condition	Método de Revisión
			x	Label	Label and Information Plates	All visible labels
		x		Installation	Winding and positioning of the rope	Working Angle
x				Operation	Appropriate functioning	Manual
	x			Circuit wiring condition	No visible damage	Visual
		x		Control/ Switch	Wear of electric contacts	Visual
		x		Wear of power cord	No visible damage	Visual
x	x			Ground Cable	No visible damage, appropriate contact	Visual
		x		Isolation	1 MQ min	Resistance Test
			x	Motor	Isolation	500V Isolation/Resistance Test
			x	Stains	Abnormality	Check failures
	x			Brake	Tighten	Check failures
		x		Bolts	No visible wear	Check failures
x	x			Wear of the disc	Not above 1.5% the wire rope length rolled in 1 min	Check failures
			x	Performance	No visible wear	Visual
			x	Gears	Use sufficient recommended lubricant (Mobilux, EP2, Shell Unedo 2, Esso Beacon EP2)	Check failures
		x		Wear	Measurement	Measurement
				Lubrication	Less than 10%	Visual
x				Steel Rope	Strand break	Visual
x				Decrease in diameter	Max. 7% of nominal diameter	Visual
x				Rust	No severe	Visual
x				Anchoring Condition	Sufficient to lift the load	Visual
x				Rolling Condition	Regular	Visual
x				Lubrication	Sufficient	Visual
x	x			Case	Structure	No damage
				Structure	No damage	Visual
x	x			Drum	Broken Tap	Visual
		x		Wear of the drum	No visible wear	Visual
x				Operation	Wind direction	Visual
x				Abnormal sounds	No oscillation or impact sound	Auditory
			x	Overload Test	Abnormality	Test



Any modification or repair without prior Prowinch®'s authorization will void the warranty of the equipment. It is your responsibility to periodically check the condition of the steel wire rope, anchor or any parts that can be worn loose or damaged in both the unit and the object to move.

TROUBLESHOOTING AND POSSIBLE SOLUTIONS

Before using the winch Prowinch®, check the drum to ensure that the wire rope is coiled properly. To ensure that the winch operates smoothly, test the control button. If winch fails after several attempts, check the following points:

- 1.** Non functioning
 - Power supply.
 - Check the Emergency Stop Switch.
- 2.** Produces noises but is not functional
 - Check the brake coil and/or circuit.
 - Check the Switch and replace the cable.
 - Check for faults in the Power Supply.
- 3.** Low velocity and vibration
 - Shortcut in the ignition capacitor.
 - Contact of the centrifugal switch.
- 4.** Ignition failure
 - Check the brake coil and/or circuit.
 - Ignition capacitor.
 - Worn brake disc.
- 5.** Brake failure or lubricant spill
 - Brake coil.
 - Brake disc.
 - Metal brake disc.
 - Brake spring.
 - Possible brake action due to voltage drop.
- 6.** Reversed direction (Three-phase equipments)
 - Phase reversal
- 7.** Electric leakage
 - Check ground connection
 - Internal circuit wiring is touching the equipment's case. Check electrical wiring and replace or repair if necessary.
- 8.** Unusual noise
 - Lubricate all moving parts, using recommended lubricators.
 - Worn gears or bearings. Check and replace if necessary.
 - Bolts or nuts loose. Check all bolts and nuts and tighten them properly.
- 9.** When pressing the switch, engine noise is heard, but it does not turn
 - Insufficient voltage from power supply.
 - Power cable length is too large.
 - Burned brake coil.

WARRANTY

1. Warranty is only valid with the receipt or legal invoice for a period of 3 years from its issue date and with the Prowinch maintenance up to date (yearly)
2. This lifting equipment, even though designed to lift or pull weight, is not intended to lift people or similar objects. People must keep away from the wire rope (or chain), hook and load.
3. The user is responsible for installing the unit with certified personnel capable of performing that labor to the norms. An accredited calculation engineer who certifies the installation must perform every structural calculation. An incorrect installation process will invalidate the unit's warranty.
4. It is the responsibility of every person who uses the equipment to operate according to ASME B30 norms. Operators are also responsible for maintenance and recordkeeping of maintenance performed on the equipment. Prowinch offers training and certifies operators.
5. In the case of performing any electric connection that differs from the user manual, the warranty will immediately expire.
6. The equipment owner is responsible for regularly checking the wire rope (or chain), hook, or any other piece of the equipment that may be loose or damaged or the load to be manipulated.
7. The user is responsible for wearing the safety equipment indicated in the manual to operate this equipment. All appropriate protective equipment must be worn, including working helmets, safety shoes, and eyeglass protection. This applies to any person surrounding the equipment.
8. The warranty will expire immediately if any intervention is done to the equipment.
9. Every Prowinch piece of equipment includes a warranty seal. In the event it is broken, the warranty will expire immediately.
10. Warranty will end if the equipment is not installed on an adequate leveled surface and without suitable perforations and anchorages.
11. It's the user's responsibility to comply with the correct electrical specifications of the equipment.
12. This warranty only covers fabrication defects.
13. This warranty will not cover any unit that may show signs of abuse, load more than the indicated weight, have evidence of burned circuits, or have broken or damaged parts.
14. It's the user's responsibility not to overload the equipment above the weight indicated on the unit's nameplate.
15. This warranty is provided by Prowinch headquarters. Replacement parts covered by this warranty are sent to the destination. Shipping and handling costs are not included and must be paid by the owner.
16. Warranty does not cover equipment transportation, unloading, personnel transportation, or any other cost related to not using the equipment.
17. If a technical visit is solicited and scheduled at the customer's site, it shall be paid in advance even though the visit involves services covered by this warranty.
18. The warranty is only valid to the direct buyer, not to other people in case of resale, renting, or passing the equipment on to others.

Warranty exclusions:

- If the damage is produced by meteorological agents.
- If the damage is produced by external agents such as: fire, water, crushing, wrong voltage usage or inadequate energy use.
- If any damage is caused by inadequate transportation, vandalism, sand or natural disasters such as earthquakes, flood or fire.

TECHNICAL PARAMETERS PWK380

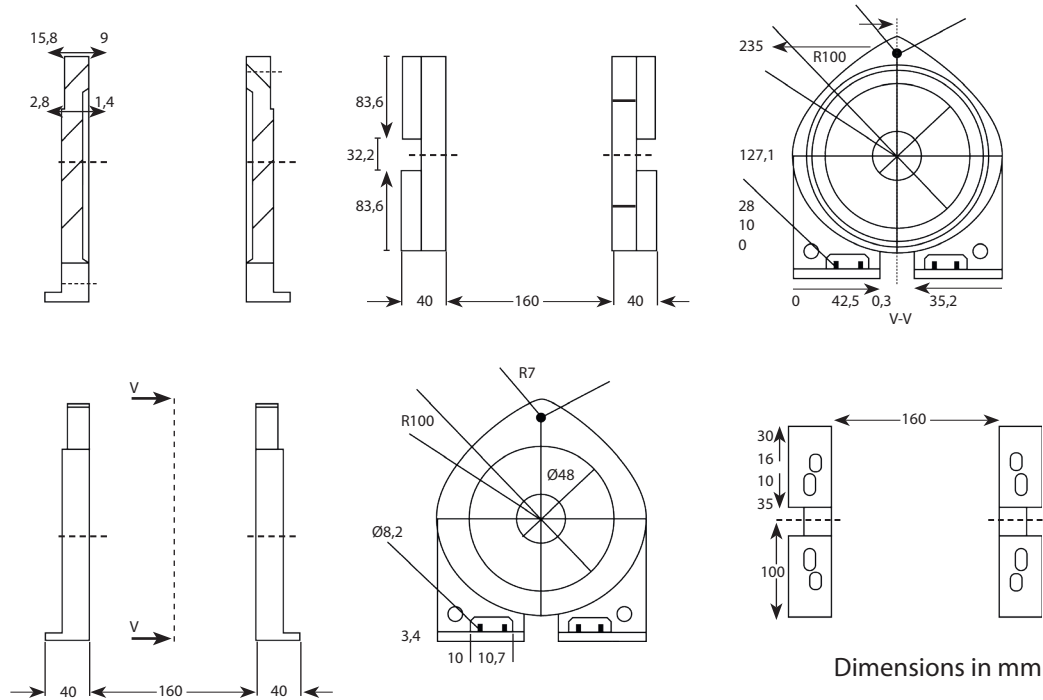

Dimensions in mm

TECHNICAL PARAMETERS

CODE	PWK380
CAPACITY	844 Lb
SPEED	50 - 68 Ft / Min
MOTOR	1,1 KW
APPLICATION	Lifting & Pulling
TOTAL WEIGHT	84 Lb
STANDARD	ASME 830.7 / B30.10 / ANSI-AWS
WRC ROPE	1/4" x 98 Ft
TOTAL RANGE	91 Ft
TRANSMISSION	Manual

WARRANTY

- 1 Year Included
- 2 Year Extended
- 10Years Parts Service Availability

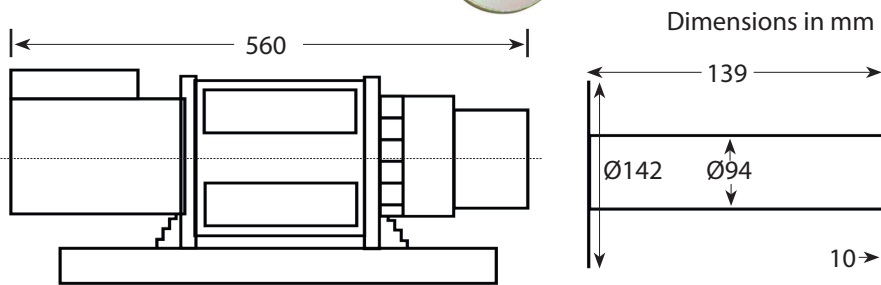
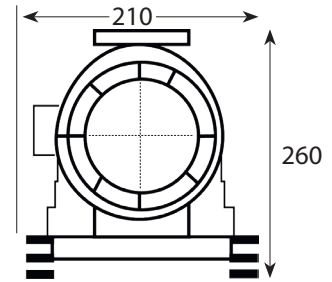

Dimensions in mm

PERFORMANCE

LAYER	ROPE ON DRUM MIN IT	LIFTING x LAYER	SPEED Ft/Min
1	21	844	50,2
2	45	755	56,1
3	72	683	62,0
4	101	623	66,0

SERVICE FACTOR

SERVICE	LOAD	TIME	MAINTENANCE
NORMAL	<65%	<25%	6 ~ 12
HEAVY	>65%	>25%	3 ~ 6
SEVERE	<100%	Duty cliche limit	1 ~ 3

VOLTAGES AVAILABLE

COUNTRY	MONOPHASE
ARGENTINA	220 ~ 240V 50Hz
CHILE	220 ~ 240V 50Hz
COLOMBIA	110 ~ 120V 60Hz
COSTA RICA	110 ~ 120V 60Hz
MEXICO	110 ~ 120V 60Hz
PERU	220 ~ 240V 50Hz
USA	110 ~ 120V 60Hz
RESTO A.L.	110 ~ 120V 60Hz

* Check for options



WIRELESS CONTROL

F21-45



PULLEY

Single & Multiple

NUMBER	DESCRIPTION
1	Remote
2	Gearbox
3	Motor
4	Key
5	Bearing
6	Sleeve
7	Motor Support Base
8	Cap Screw
9	Bushing
10	Bushing
11	Hook
12	Weight
13	Drum
14	Steel Cable
15	Plate
16	Bushing
17	Bearing
18	Pinion
19	Axis
20	Reducer Support Base
21	Golilla Pressure
22	Nut
23	Bearing
24	Gearbox housing
37	Brake hub
38	Spring Brake
39	Retainer
40	Brake Hub
41	O ring
42	Brake coil
43	Brake plate
44	Disc Brake
45	Brake plate
46	Plastic top

PWK380 PART LIST

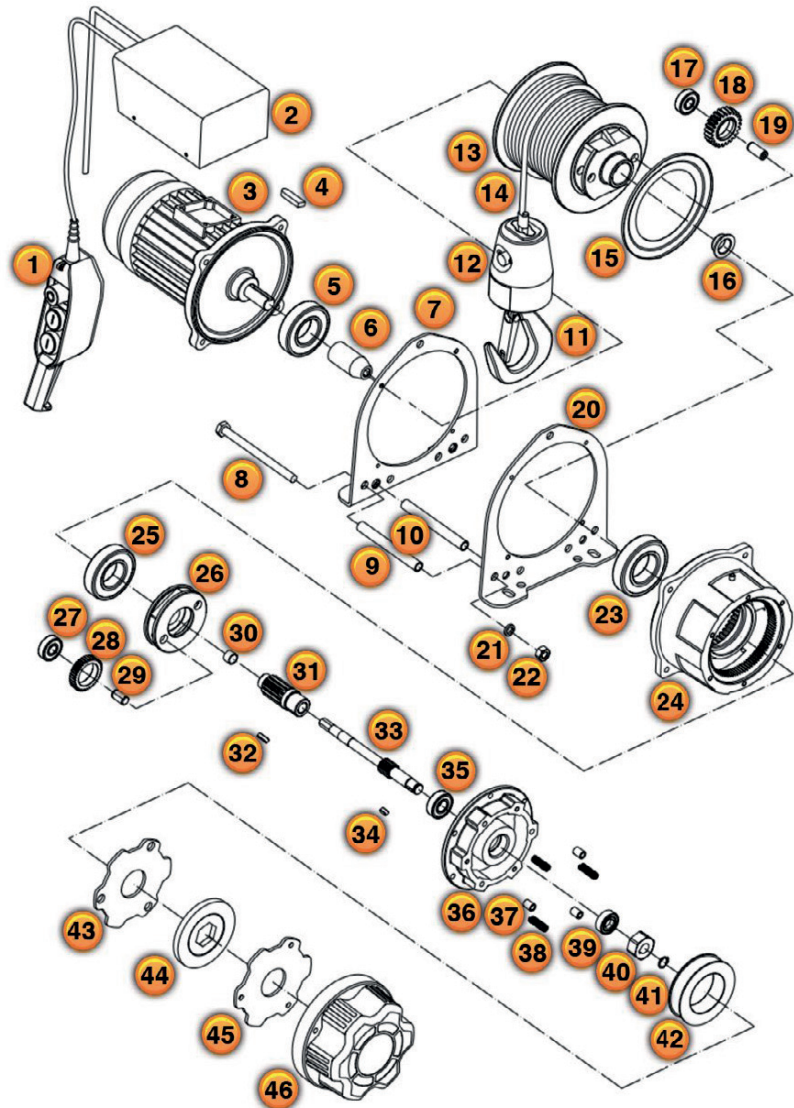

TECHNICAL PARAMETERS

PWG450i

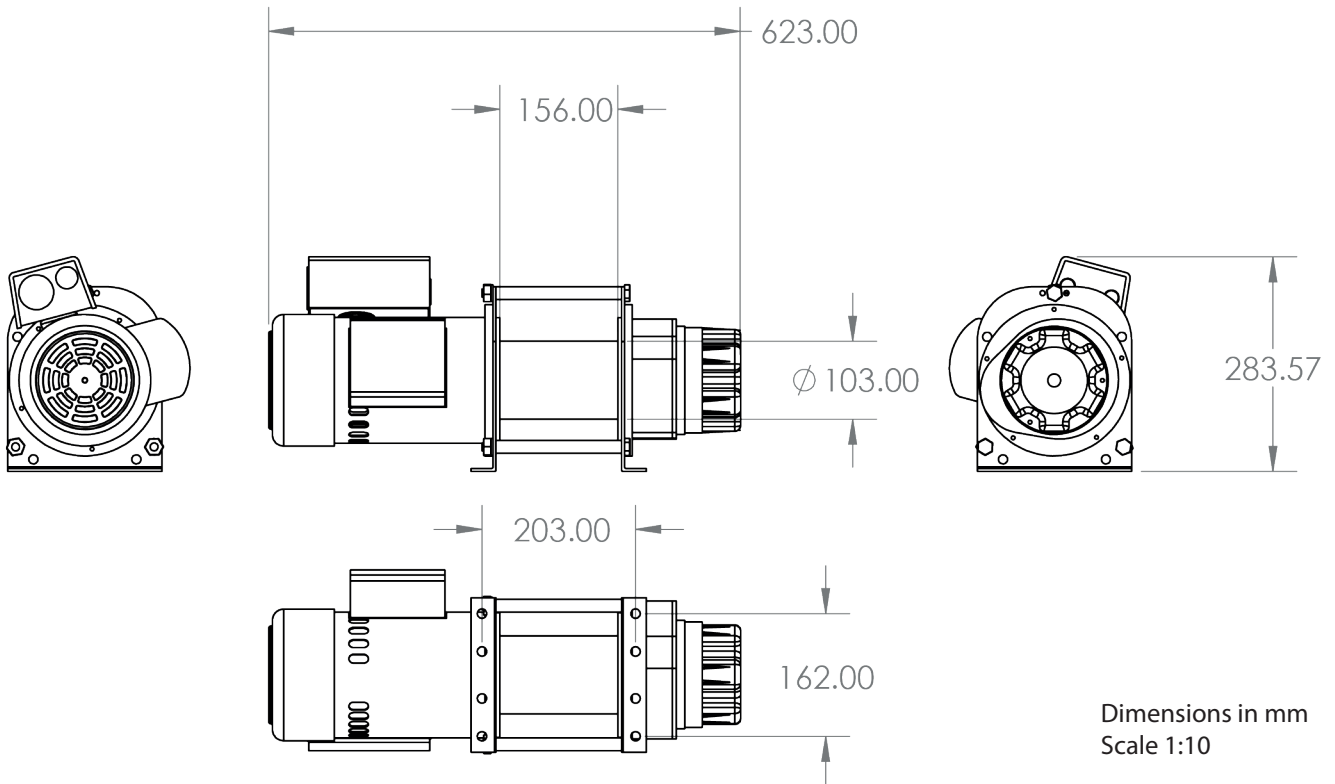

CODE	PWG450i
CAPACITY	992 Lb
SPEED	72 - 121 Ft / Min
MOTOR	4 x 1,8 KW
VOLTAGE	120V / 220V 50/60 hZ 1Ph
TOTAL WEIGHT	110 Lb
STANDARD	ASME B30.7 / B30.10 / ANSI-AWS
WRC ROPE	Ø1/4" x 98 Ft
TOTAL RANGE	91 Ft
ELECTROMAGNETIC BRAKE	>125%

WARRANTY

- 1 Year Included
- 2 Year Extended
- 10Years Parts Service Availability

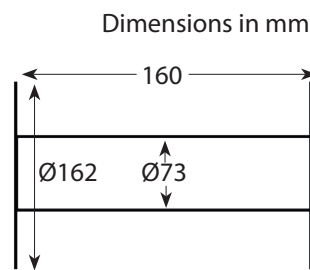
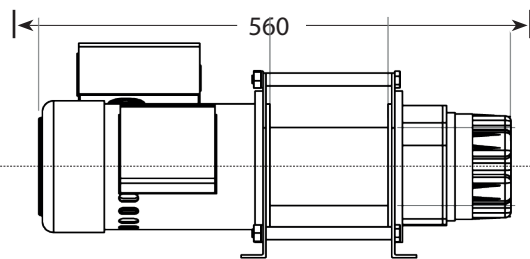
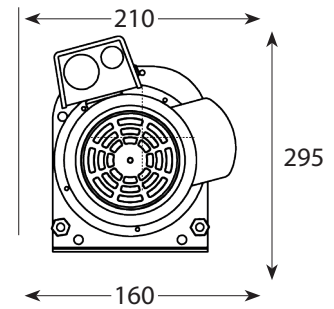

Dimensions in mm

PERFORMANCE

LAYER	ROPE ON DRUM MIN IT	LIFTING x LAYER	SPEED Ft/Min
1	23	1054	81,6
2	49	943	91,2
3	78	854	100,7
4	109	780	110,3
5	143	718	119,8

SERVICE FACTOR

SERVICE	LOAD	TIME	MAINTENANCE
NORMAL	<65%	<25%	6 ~ 12
HEAVY	>65%	>25%	3 ~ 6
SEVERE	<100%	Duty cicle limit	1 ~ 3

VOLTAGES AVAILABLE

COUNTRY	MONOPHASE
ARGENTINA	220 ~ 240V 50Hz
CHILE	220 ~ 240V 50Hz
COLOMBIA	110 ~ 120V 60Hz
COSTA RICA	110 ~ 120V 60Hz
MEXICO	110 ~ 120V 60Hz
PERU	220 ~ 240V 50Hz
USA	110 ~ 120V 60Hz
RESTO A.L.	110 ~ 120V 60Hz

* Check for options



WIRELESS CONTROL
PWG600-450-CR



HOOK
PWG600HO

N°	DESCRIPTION	Q
1	Bolts	4
2	Motor cover	1
3	Bearing	1
4	Rotor	1
5	Fan cover	1
6	Spring lock	1
7	Bearing	1
8	Oil seal	1
9	Bolts	2
10	Stator	1
11	Main base	1
12	Registry	1
13	Bolts	4
14	Resistance	1
15	Bolts	2
16	Bridge rectifier	2
17	Cap screw	2
18	Rubber band	1
19	Base and coals	2
20	Carbon cover	2
21	Rubber band	1

N°	DESCRIPTION	Q
22	Control plug	1
23	Bolts	1
24	Current input	3
25	Bolts	1
26	Packing	2
27	Bearing	1
28	Spring	1
29	1st section pinion	1
30	Spring	1
31	Bearing	1
32	Bearing	1
33	Key	1
34	1st section axis	1
35	Coupling	1
36	Bearing	1
37	Bearing	2
38	Oil seal	3
39	Hex bolt	1
40	Nut with cap	4
41	Engine support rack	1
42	Bearing	1

N°	DESCRIPTION	Q
43	Hex bolt	6
44	Cap screw	1
45	Drum	1
46	Output shaft	1
47	Oil seal	1
48	Bearing	1
49	Bar	1
50	Bar	2
51	Transmission support rack	1
52	Gear 3 "	1
53	Retention ring	1
54	Second Axis	1
55	Bearing	2
56	Packing	1
57	Transmission cover	1
58	Hex bolt	6
59	O-ring	1
60	Hex bolt	1
61	Fan	1
62	Fan cover	1
63	Cross bolts	3

N°	DESCRIPTION	Q
64	insurance	2
65	Spring pin	2
66	Pinion	1
67	Ratchet wheel	1
68	Disc brake	1
69	Third axis	1
70	Bearing	1
71	Safe bolts	2
72	Spring	2
73	Ratchet wheel	2
74	Steel wire	1
75	Weighted hook	1

PWG450i PART LIST

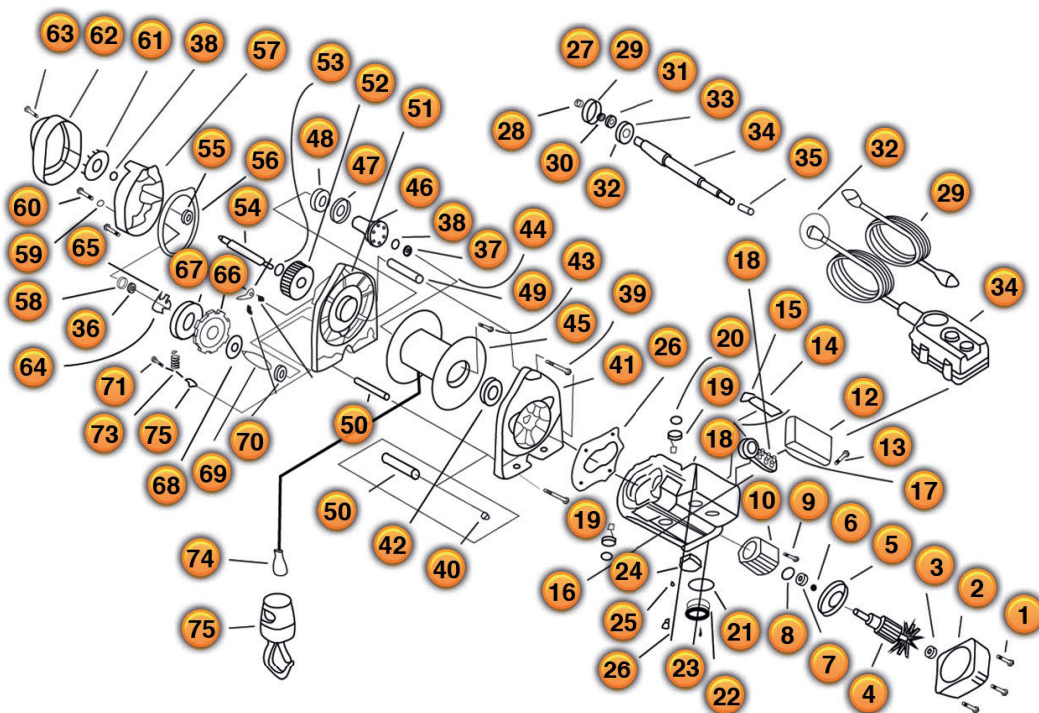

TECHNICAL PARAMETERS PWG600

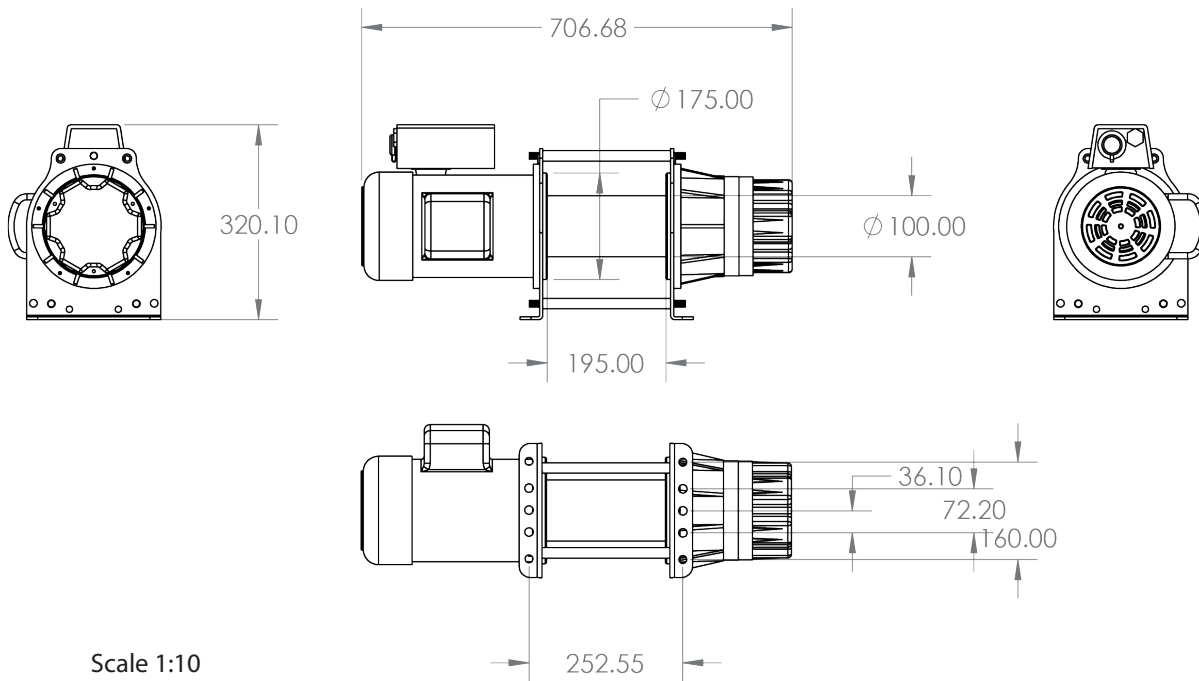
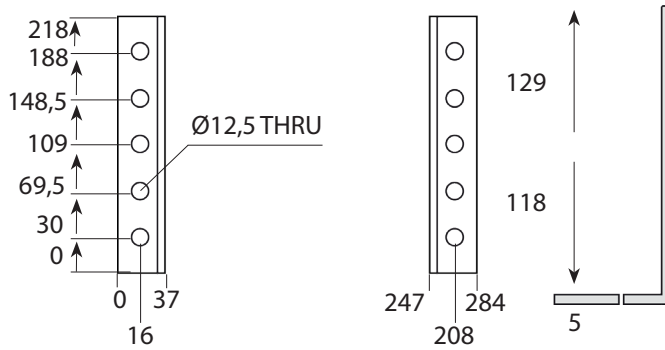
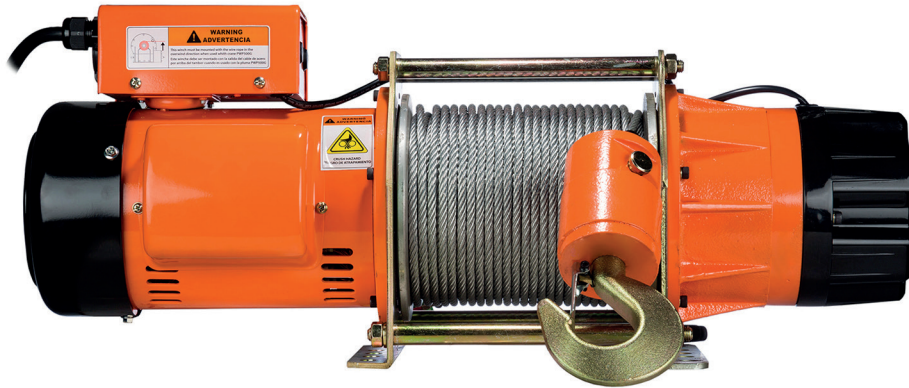

Scale 1:10
Dimension in mm

TECHNICAL PARAMETERS

CODE	PWG450i
CAPACITY	1.340 Lb
SPEED	42 - 72 Ft / Min
MOTOR	2 Hp
VOLTAGE	120V / 220V 50/60 Hz Ph
TOTAL WEIGHT	235 Lb
STANDARD	ASME B30.7 / B30.10 / ANSI-AWS
WRC ROPE	Ø1/4" x 196 Ft
TOTAL RANGE	165 Ft
ELECTROMAGNETIC BRAKE	Simple disc direct on reductor capacity>125%
APPLICATION	Lifting & Pulling

SERVICE FACTOR

SERVICE	LOAD	TIME	MAINTENANCE
NORMAL	<65%	<25%	6 ~ 12
HEAVY	>65%	>25%	3 ~ 6
SEVERE	<100%	Duty cliche limit	1 ~ 3

WARRANTY:

- 1 Year Included
- 2 Year Extended
- 10 Year Parts Service Availability

PERFORMANCE

LAYER	ROPE ON DRUM Ft	LIFTING x LAYER	SPEED Ft/Min
1	25	1,340	42,5
2	54	1,176	48,4
3	67	1,048	54,4
4	123	945	50,3
5	163	861	66,2
6	206	790	72,1

PERFORMANCE

LAYER	ROPE ON DRUM Ft	LIFTING x LAYER	SPEED Ft/Min
1	32	1,340	42,5
2	67	1,206	47,2
3	106	1,097	52,0
4	149	1,005	56,7
5	195	928	61,4
6	75	391	20,2
7	91	365	21,6

VOLTAGES AVAILABLE

COUNTRY	MONOPHASE
ARGENTINA	220V ~ 240V 50Hz
CHILE	220V ~ 240V 50Hz
COLOMBIA	110V ~ 120V 50Hz
COSTA RICA	110V ~ 120V 50Hz
MEXICO	110V ~ 120V 50Hz
PERU	220V ~ 240V 60Hz
USA	110V ~ 120V 60Hz
REST A.L.	110V ~ 120V 60Hz

* Check for options



WIRELESS CONTROL

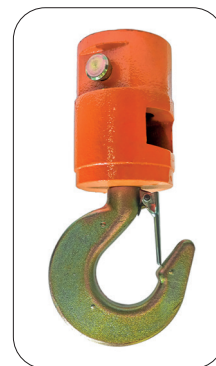

HOOK
PWG600HO

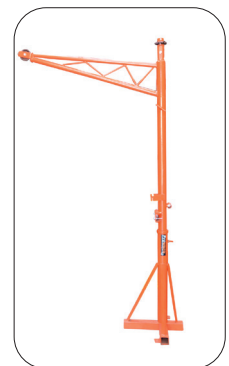

PLUMES
PWP500G

N°	DESCRIPTION	Q
1	Motor	1
2	Bridge rectifier	1
3	Hex bolt	11
4	Golilla pressure	11
5	Engine / Transmission Base	2
6	Nut	3
7	Golilla pressure	3
8	Bearing	1
9	Drum	1
10	Cable insurance	1
11	Steel wire	1
12	Oil gear phase 2	2
13	Bearing	6
14	Barrette	14
15	Bar	3
16	Hex bolt	3
17	Bearing	1
18	Phase 2 axis	1
19	Key	1
20	Bearing	1
21	Transmission box	1
22	Bearing	1

N°	DESCRIPTION	Q
23	Gear Phase 1	1
24	Barrette	1
25	Transmission sleeve	1
26	Bearing	1
27	1st Phase Axis	1
28	Key	1
29	Bearing	1
30	Spool Holder	2
31	Bolts	1
32	Brake springs	3
33	Plug cable	1
34	Command control	1
35	Brake coil	1
36	Magnetic plate A	1
37	Brake disc	1
38	Transmitter head nut	1
39	insurance	1
40	Magnetic plate B	1
41	Brake cover	1
42	Flat golilla	1
43	Bolts	6
44	Bolts	3
45	Brake sleeve	3
46	Weighted hook	1

PWG600 PART LIST

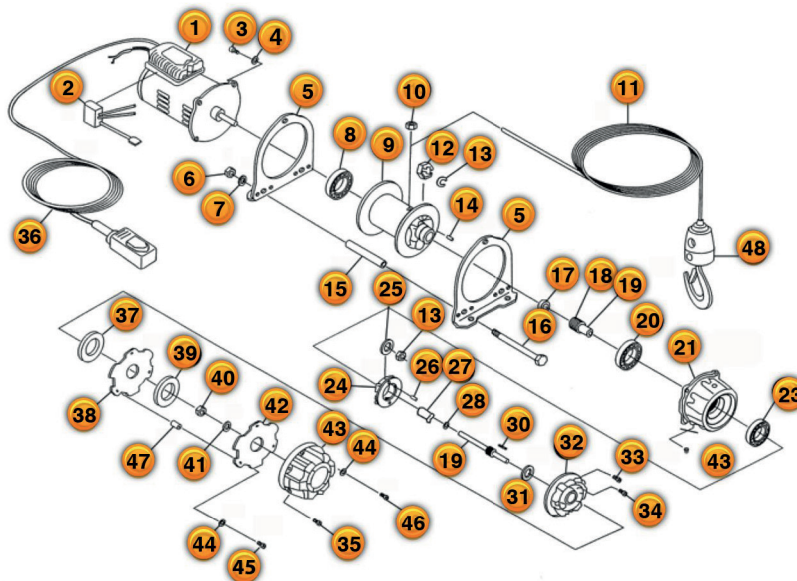

TECHNICAL PARAMETERS PWK625i

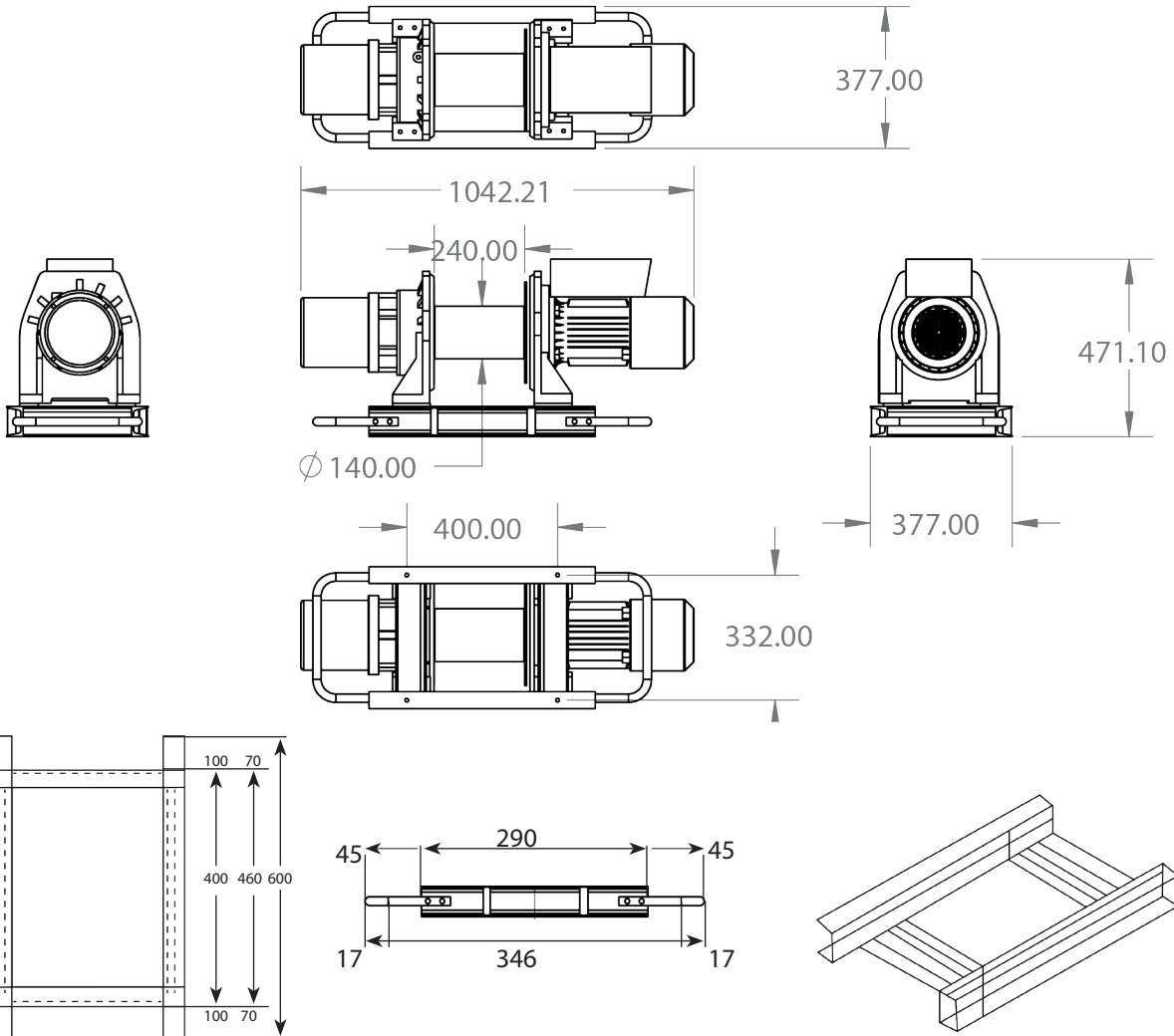
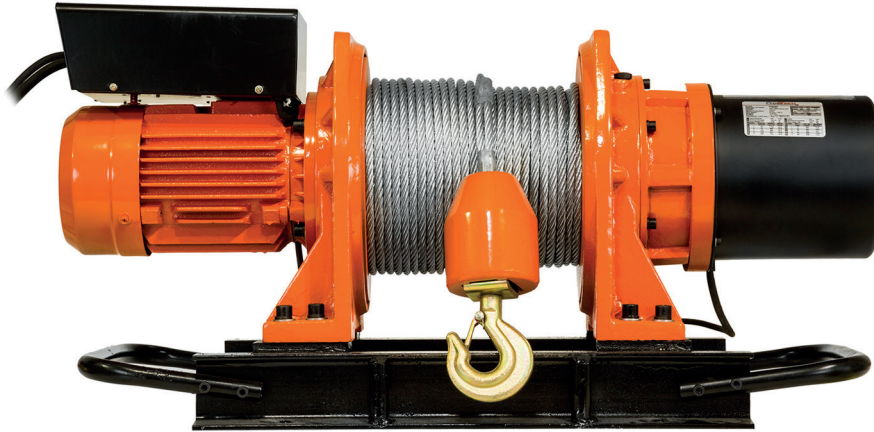

Scale 1:20
Dimension in mm

TECHNICAL PARAMETERS

CODE	PWG450i
CAPACITY	1.433 Lb
SPEED	40 - 58 Ft / Min
MOTOR	2 Hp
VOLTAGE	120V / 220V 50/60 Hz 1Ph
TOTAL WEIGHT	343 Lb
STANDARD	ASME B30.7 / B30.10 / ANSI-AWS
WRC ROPE	Ø3/8" x 328 Ft
TOTAL RANGE	318 Ft
ELECTROMAGNETIC BRAKE	Double disc direct on reductor capacity>125%
APPLICATION	Lifting & Pulling

SERVICE FACTOR

SERVICE	LOAD	TIME	MAINTENANCE
NORMAL	<65%	<25%	6 ~ 12
HEAVY	>65%	>25%	3 ~ 6
SEVERE	<100%	Duty cicle limit	1 ~ 3

WARRANTY:

1 Year Included

2 Year Extended

10 Year Parts Service Availability

PERFORMANCE INCLUDED

LAYER	ROPE ON DRUM Ft	LIFTING x LAYER	SPEED Ft/Min
1	47	1,433	40,0
2	98	1,311	43,7
3	154	1,208	47,4
4	214	1,120	51,1
5	278	1,044	54,8
6	347	978	56,6
7	420	919	62,3
8	497	858	60,0
9	579	621	60,7
10	665	780	73,4

PERFORMANCE OPTIONAL

LAYER	ROPE ON DRUM Ft	LIFTING x LAYER	SPEED Ft/Min
1	40	1,433	40,0
2	65	1,292	44,3
3	133	1,177	48,7
4	187	1,080	53,0
5	244	899	57,3
6	306	928	61,7
7	372	567	66,0
8	443	814	70,4
9	518	766	74,7
10	598	724	79,1

VOLTAGES AVAILABLE

COUNTRY	MONOPHASE
ARGENTINA	220V ~ 240V 50Hz
CHILE	220V ~ 240V 50Hz
COLOMBIA	110V ~ 120V 50Hz
COSTA RICA	110V ~ 120V 50Hz
MEXICO	110V ~ 120V 50Hz
PERU	220V ~ 240V 60Hz
USA	110V ~ 120V 60Hz
REST A.L.	110V ~ 120V 60Hz



WIRELESS CONTROL



CONTROLLER

* Check for options

N°	DESCRIPTION	Q
1	Remote Control	1
2	Power Cord	1
3	Electric Box	1
4	Induction Motor	1
5	Key	1
6	Motor base	1
7	Bearing	1
8	Sleeve	1
9	Drum	1
10	Steel wire	1
11	Block	1
12	Hook	1
13	Axis	1
14	Coupling bushing	1
15	Segers insurance	1
16	Bearing	1
17	Lubrication plug	1
18	Transmission base	1
19	Chassis	1
20	Oil seal	1
21	Bearing	1
22	Bushing	1

N°	DESCRIPTION	Q
23	Key	
24	Axis of force	
25	Round nut	
26	Pressure gauge	
27	2nd pinion shaft	
28	Pinion 2nd	
29	Bearing	
30	Sergers Insurance	
31	Shaft Insurance Segers	
32	Oil seal	
33	Bearing	
34	Principal axis	
35	Key	
36	Second axis	
55	Axle bushing	
56	Brake depressor	
57	Brake base	
58	Brake shaft	
59	Brake spring	
60	Nut	
61	Adjustment bolt	
62	Support base	
63	Electromagnet	
64	Connection plug	

65	Connection plate	
66	Connection plug	
67	O-ring	
68	Connection plug	
69	Connection plate	
70	Support	
71	Plug	
72	Plastic brake cover	

PWG625i PART LIST

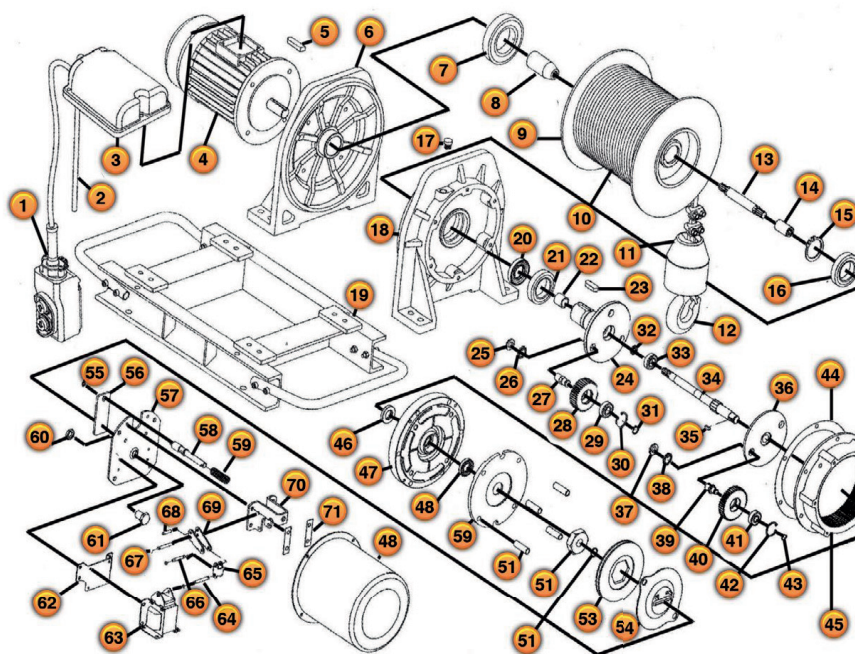

TECHNICAL PARAMETERS

PWK1250

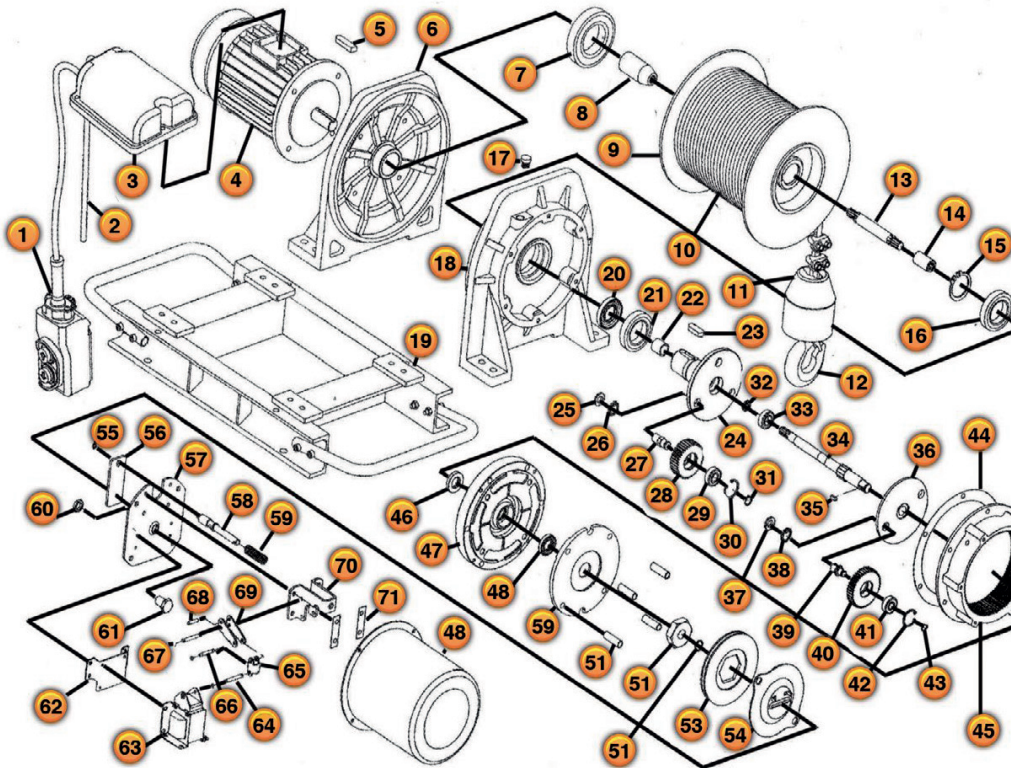

Scale 1:10
 Dimension in mm

TECHNICAL PARAMETERS

CODE	PWK1250
CAPACITY	2.846 Lb
SPEED	40 - 58 Ft / Min
MOTOR	3KW
VOLTAGE	380V / 440V / 460V 50/60 Hz 3Ph
TOTAL WEIGHT	343 Lb
STANDARD	ASME B30.7 / B30.10 / ANSI-AWS
WRC ROPE	Ø3/8" x 328 Ft
TOTAL RANGE	318 Ft
ELECTROMAGNETIC BRAKE	Double disc direct on reductor capacity>125%
APPLICATION	Lifting & Pulling

SERVICE FACTOR

SERVICE	LOAD	TIME	MAINTENANCE
NORMAL	<65%	<25%	6 ~ 12
HEAVY	>65%	>25%	3 ~ 6
SEVERE	<100%	Duty cliche limit	1 ~ 3

WARRANTY:

- 1 Year Included
- 2 Year Extended
- 10 Year Parts Service Availability

PERFORMANCE INCLUDED

LAYER	ROPE ON DRUM Ft	LIFTING x LAYER	SPEED Ft/Min
1	47	2.846	40,0
2	96	2.604	43,7
3	154	2.399	47,4
4	214	2.225	51,1
5	278	2.074	54,8
6	347	1.292	58,6

PERFORMANCE OPTIONAL

LAYER	ROPE ON DRUM Ft	LIFTING x LAYER	SPEED Ft/Min
1	40	2.846	40,0
2	85	2.567	44,3
3	133	2.338	48,7
4	187	2.146	53,0
5	244	1.983	57,3

VOLTAGES AVAILABLE

COUNTRY	MONOPHASE
ARGENTINA	380V 50Hz
CHILE	380V 50Hz
COLOMBIA	220V60HZ / 440V60HZ
COSTA RICA	220V60HZ / 440V60HZ
MEXICO	220V60HZ / 440V60HZ
PERU	220V60HZ / 440V60HZ
USA	220V60HZ / 440V60HZ
REST A.L.	220V60HZ / 440V60HZ

* Check for options



WIRELESS CONTROL



HOOK

N°	DESCRIPTION	Q
1	Remote Control	1
2	Power Cord	1
3	Electric Box	1
4	Induction Motor	1
5	Key	1
6	Motor base	1
7	Bearing	1
8	Sleeve	1
9	Drum	1
10	Steel wire	1
11	Block	1
12	Hook	1
13	Axis	1
14	Coupling bushing	1
15	Segers insurance	1
16	Bearing	1
17	Lubrication plug	1
18	Transmission base	1
19	Chassis	1
20	Oil seal	1
21	Bearing	1
22	Bushing	1

N°	DESCRIPTION	Q
23	Key	1
24	Axis of force	1
25	Round nut	3
26	Pressure gauge	3
27	2nd pinion shaft	3
28	Pinion 2nd	3
29	Bearing	3
30	Sergers Insurance	3
31	Shaft Insurance Segers	1
32	Oil seal	1
33	Bearing	1
34	Principal axis	1
35	Key	1
36	Second axis	1
55	Axle bushing	1
56	Brake depressor	1
57	Brake base	1
58	Brake shaft	1
59	Brake spring	1
60	Nut	1
61	Adjustment bolt	1
62	Support base	1
63	Electromagnet	1
64	Connection plug	2

65	Connection plate	1
66	Connection plug	1
67	O-ring	6
68	Connection plug	1
69	Connection plate	1
70	Support	1
71	Plug	2
72	Plastic brake cover	1

PWK1250i PART LIST

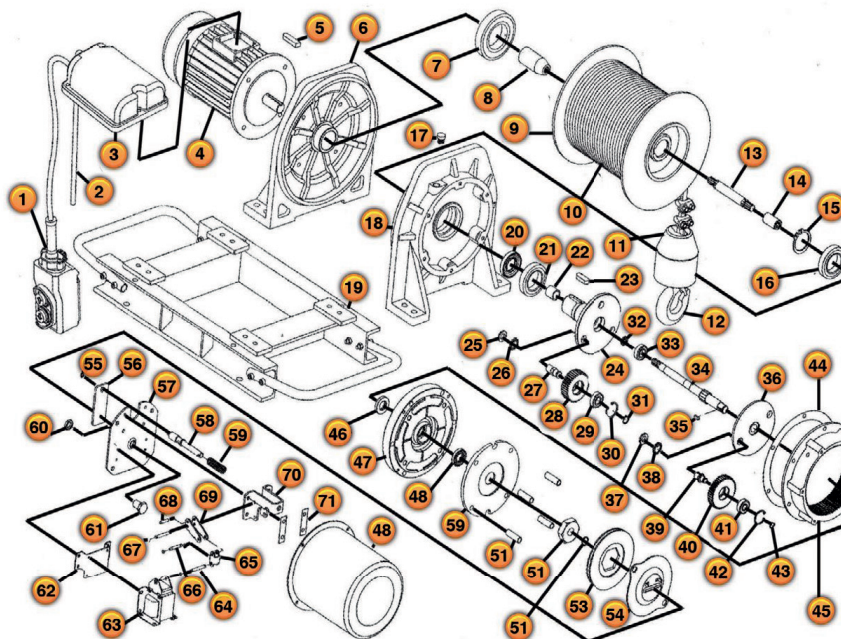

TECHNICAL PARAMETERS PWG1750i

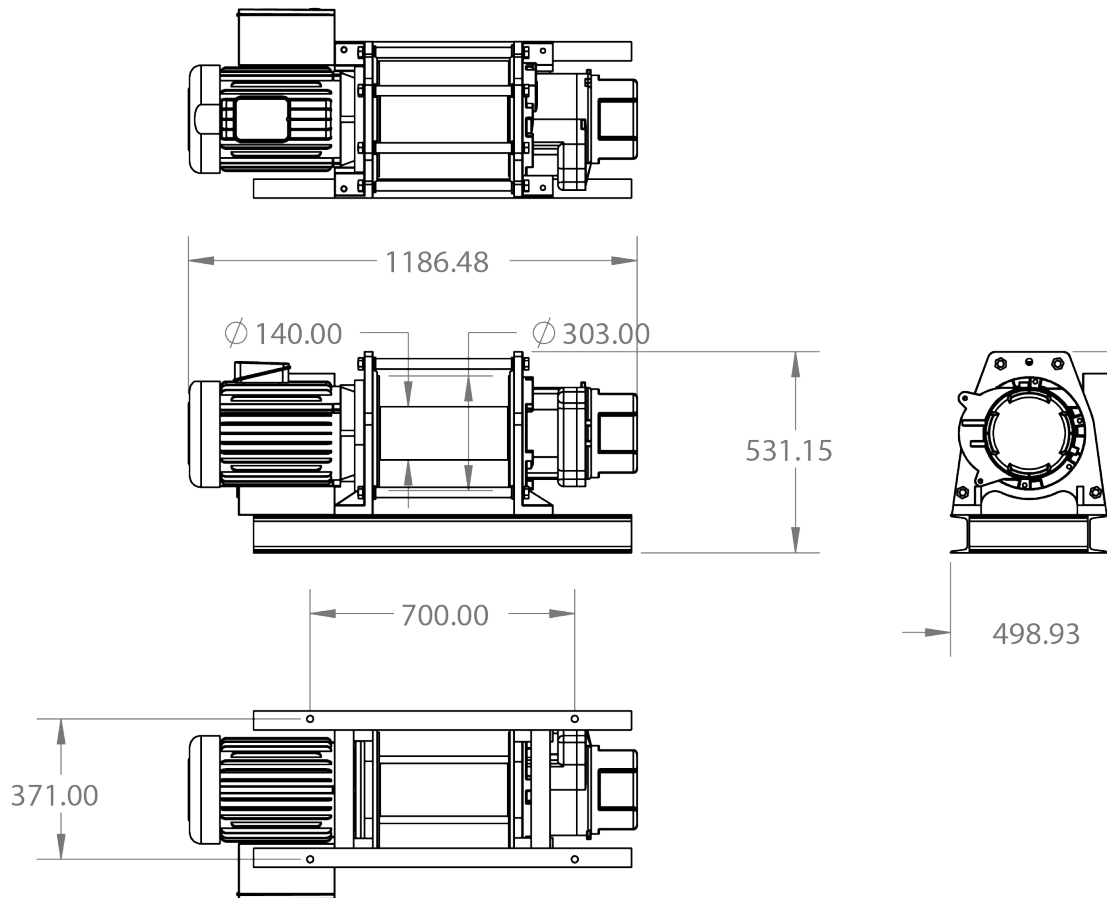
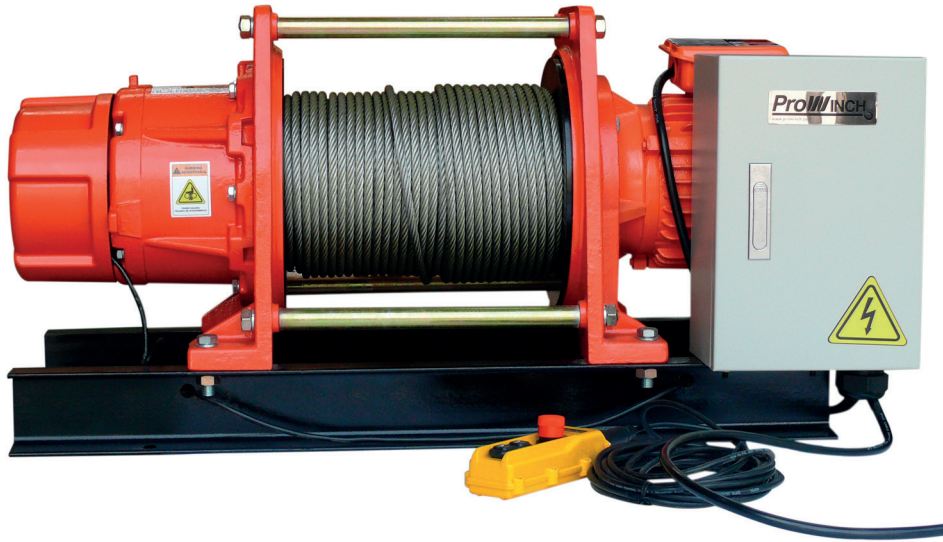

Scale 1:20
Dimension in mm

TECHNICAL PARAMETERS

CODE	PWG1750i
CAPACITY	3.800 Lb
SPEED	22 - 34 Ft / Min
MOTOR	3KW
VOLTAGE	120/220V/240V 50/60 Hz 1Ph
TOTAL WEIGHT	343 Lb
STANDARD	ASME B30.7 / B30.10 / ANSI-AWS
WRC ROPE	Ø3/8" x 328 Ft
TOTAL RANGE	318 Ft
ELECTROMAGNETIC BRAKE	Double disc direct on reductor capacity>125%
APPLICATION	Lifting & Pulling

SERVICE FACTOR

SERVICE	LOAD	TIME	MAINTENANCE
NORMAL	<65%	<25%	6 ~ 12
HEAVY	>65%	>25%	3 ~ 6
SEVERE	<100%	Duty cliche limit	1 ~ 3

WARRANTY:

- 1 Year Included
- 2 Year Extended
- 10 Year Parts Service Availability

PERFORMANCE INCLUDED

LAYER	ROPE ON DRUM Ft	LIFTING x LAYER	SPEED Ft/Min
1	59	3.858	22,1
2	126	3.385	25,2
3	202	3.015	28,3
4	286	2.718	31,4
5	378	2.474	34,5

PERFORMANCE OPTIONAL

LAYER	ROPE ON DRUM Ft	LIFTING x LAYER	SPEED Ft/Min
1	69	3.858	22,1
2	146	3.445	24,8
3	232	3.133	27,4
4	325	2.389	30,0
5	427	2.609	32,7
6	538	2.414	35,3
7	656	2.245	38.0

VOLTAGES AVAILABLE

COUNTRY	MONOPHASE
ARGENTINA	220V - 240V 50Hz
CHILE	220V - 240V 50Hz
COLOMBIA	110V - 120V 60Hz
COSTA RICA	110V - 120V 60Hz
MEXICO	110V - 120V 60Hz
PERU	220V - 240V 60Hz
USA	110V - 120V 60Hz
REST A.L.	110V - 120V 60Hz

* Check for options



WIRELESS CONTROL



HOOK

N°	DESCRIPTION	Q
1	Command Control	1
2	Power Cord	1
3	Control box	1
4	Motor	1
5	Key	1
6	Engine side base	1
7	Bearing	1
8	Sleeve Shaft	1
9	Drum	1
10	IWRC cable	1
11	Hook Weight	1
12	Hook	1
13	Drum Shaft	1
14	Sleeve Shaft	1
15	Segers insurance	1
16	Bearing	1
17	Lubrication Cap	1
18	Base Side Reducer	1
19	Chassis	1
20	Oil seal	1
21	Bearing	1
22	Shirt	1
23	Key	1
24	Plate	1

N°	DESCRIPTION	Q
23	Nut	3
24	Pressure gauge	3
25	Second axis	3
26	Second Pinion	3
27	Bearing	3
28	Segers Insurance	3
29	Golilla	3
30	Retainer	3
31	Bearing	3
32	Axis	1
33	Reducer	1
34	Plate	1
35	Golilla Plana	1
36	Golilla	1
37	First Axis	2
38	Pinion First	2
39	Bearing	2
40	Segers insurance	2
41	Golilla	2
42	Packing	2
43	Reducer Housing	2
44	Bearing	1
45	Reducer cover	1
46	Retainer	1

49	Brake Support Plate	1
50	Brake Spacers	4
51	Brake Sleeve	1
52	Golilla	1
53	Disc Brake	1
54	Brake Press	1
55	Golilla	1
56	Brake Depressor	1
57	Brake Prta Plate	1
58	Brake Axle	1
59	Spring Brake	1
60	Nut	1
61	Adjustment Bolt	1
62	Release Support	1
63	Electro Magnetic Release	1
64	Barrette	2
65	Pin Support	1
66	Pin Support	1
67	Barrette	6
68	Barrette	1
69	Connection Plate	1
70	Support plate	1
71	Limiter	2
72	Brake Cover	1

PWK1250i PART LIST

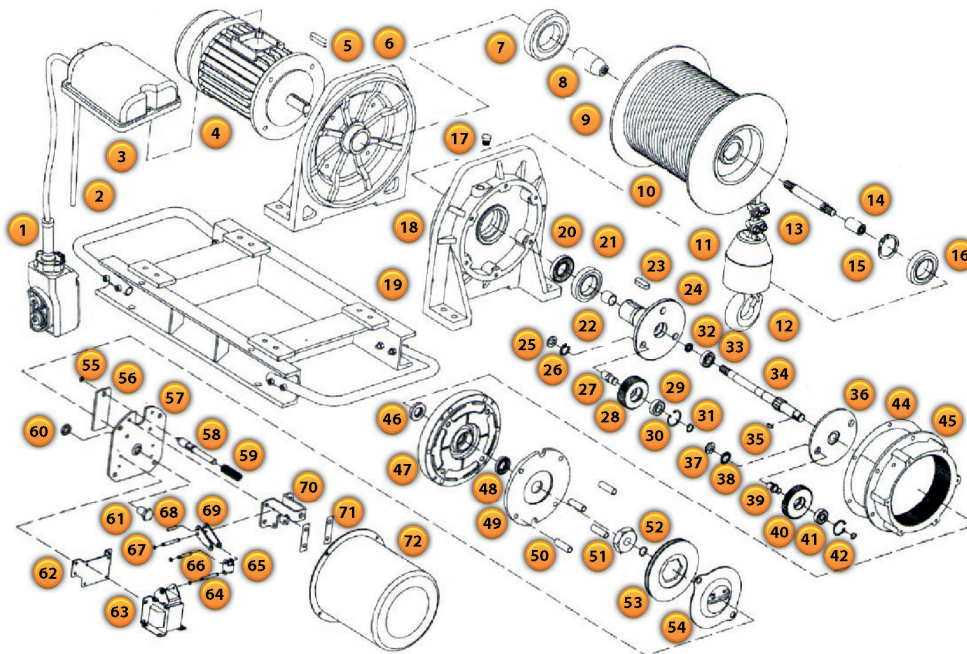

TECHNICAL PARAMETERS

PWK2900i

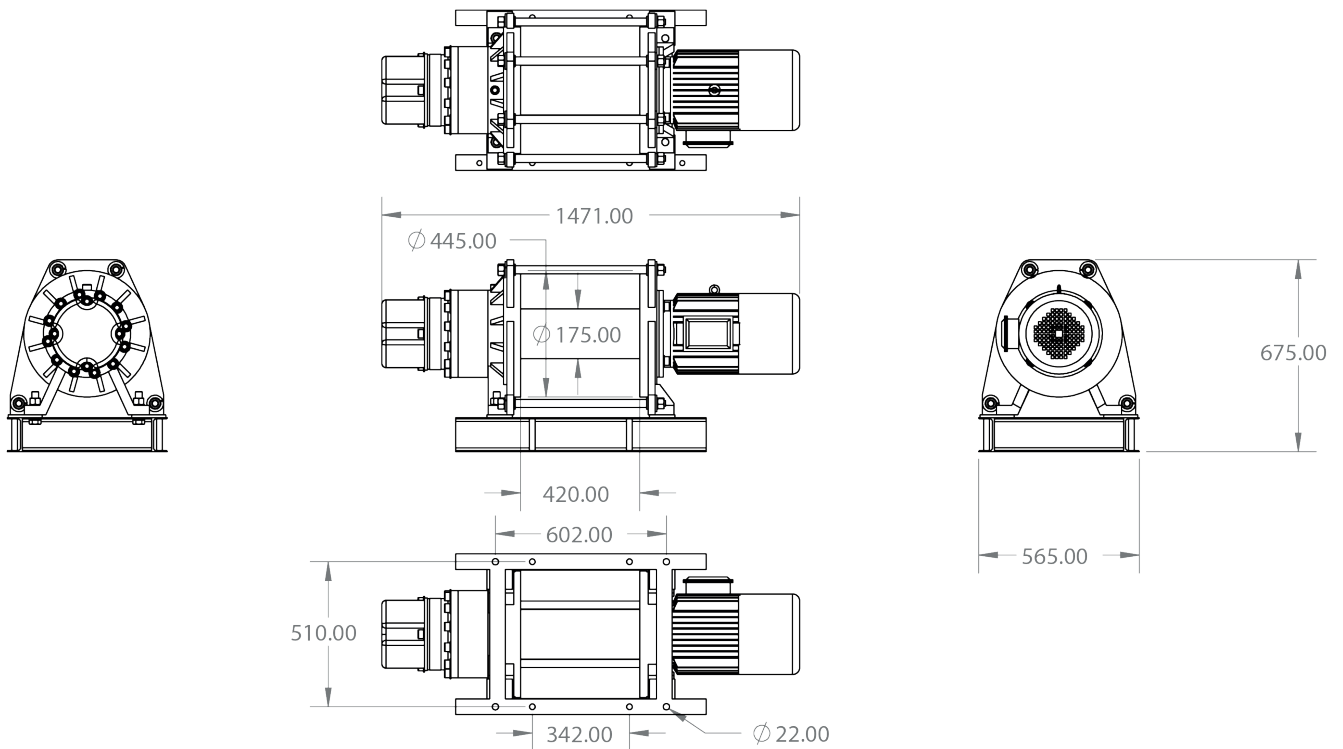

Scale 1:20
Dimension in mm

TECHNICAL PARAMETERS

CODE	PWK2900i
CAPACITY	6.448 Lb
SPEED	22 - 34 Ft / Min
MOTOR	6KW
VOLTAGE	220V/380V/440V/460V 50/60 Hz 3Ph
TOTAL WEIGHT	992 Lb
STANDARD	ASME B30.7 / B30.10 / ANSI-AWS
WRC ROPE	Ø1/2" x 492 Ft
TOTAL RANGE	482 Ft
ELECTROMAGNETIC BRAKE	Double disc direct on reductor capacity>125%
APPLICATION	Lifting & Pulling

SERVICE FACTOR

SERVICE	LOAD	TIME	MAINTENANCE
NORMAL	<65%	<25%	6 ~ 12
HEAVY	>65%	>25%	3 ~ 6
SEVERE	<100%	Duty cliche limit	1 ~ 3

WARRANTY:

- 1 Year Included
- 2 Year Extended
- 10 Year Parts Service Availability

PERFORMANCE INCLUDED

LAYER	ROPE ON DRUM Ft	LIFTING x LAYER	SPEED Ft/Min
1	44	6.449	34,9
2	94	5.713	39,3
3	149	5.127	43,8
4	210	4.551	48,3
5	277	4.256	52,8
6	349	3.922	57,3
7	427	3.637	61,8
8	511	3.391	66,3

PERFORMANCE OPTIONAL

LAYER	ROPE ON DRUM Ft	LIFTING x LAYER	SPEED Ft/Min
1	40	6.449	34,9
2	86	6.553	39,8
3	138	5.032	44,7
4	195	4.534	40,6
5	258	4.128	54,5
6	327	3.785	59,4

VOLTAGES AVAILABLE

COUNTRY	MONOPHASE
ARGENTINA	380V 50HZ
CHILE	380V 50HZ
COLOMBIA	220V60Hz / 440V60Hz
COSTA RICA	220V60Hz / 440V60Hz
MEXICO	220V60Hz / 440V60Hz
PERU	220V60Hz / 440V60Hz
USA	220V60Hz / 440V60Hz
REST A.L.	220V60Hz / 440V60Hz

* Check for options



WIRELESS CONTROL



CONTROL PANEL



CONTROLLER

N°	DESCRIPTION
1	M8X20 Cylindrical Hex Bolt
2	Protective cover
3	M12 Hex Nut
4	Main disk
5	Spring Ø20x25 Ø2.6X
6	Substitute disk
7	Brake disc
8	Steel brake disc
9	Double end bolt
10	Hexagonal cylindrical bolt M10x30
11	Brake support disc
12	Segers Ø34 lock
13	Hexagonal cylindrical bolt
14	Disc shaft
15	Oil seal Ø55 x 8 Ø35X
16	Bearing disc
17	Bearing
18	Key
19	Triple axle
20	Planetary pinion
21	Retaining ring Ø55
22	Planetary pinion
23	Sprocket 6006
24	Planetary pinion

N°	DESCRIPTION
23	Golilla Ø 25
24	Planetary frame
25	Lock rings Ø 25
26	Round nut M25
27	Hexagonal cylinder bolt M10 x 140
28	Ring terminal pad
29	Ø 65 Golilla damping
30	Bearing 6206
31	Two-level planetary pinion
32	Two Level Planetary Wheel Carrier
33	Two-level planetary shaft
34	Pinion
35	Thick golilla
36	Three-tier planetary frame
37	Ø 40 axial damping elastic ring
38	Bearing 6008 and 6017
39	Fluted housing
40	Oil seal 35x8 Ø55K
41	22x80 key
42	Second / third internal sprocket
43	Hex nut
44	Gearbox reduction bearing
45	Pitman axle
46	

49	Oil seal Ø 85x155 Ø 120X
50	Flat, cross and recessed bolt
51	Cable fixing plant
52	Cable module
53	Sprocket 6021
54	Motor bearing
55	Motor shaft
56	Coupling
57	Key
58	Y132-4 Engine
59	Hex bolt
60	Electric cabinet
61	Control box
62	Electricity cable
63	Chassis
64	Steel cable with hook

PWK2900i PART LIST

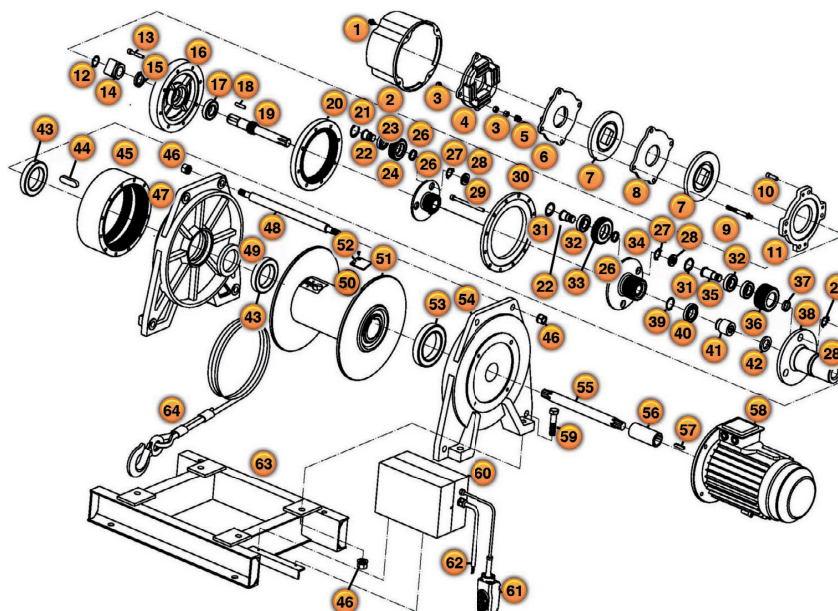

TECHNICAL PARAMETERS

PWK4300i

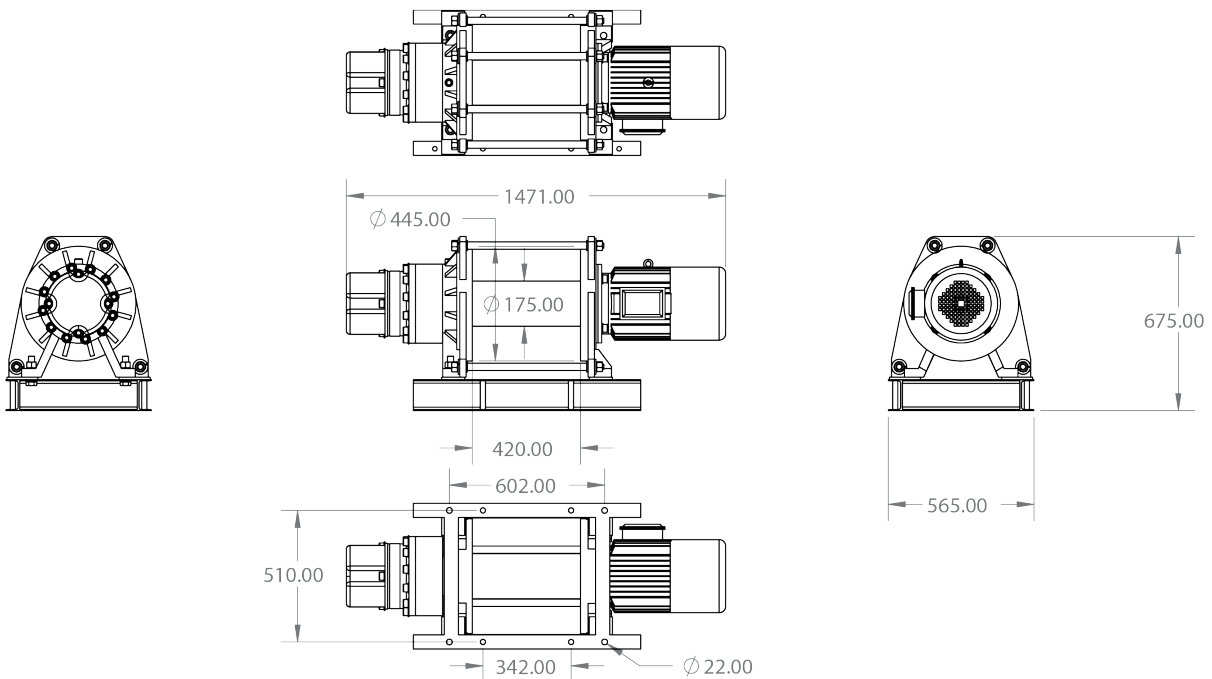
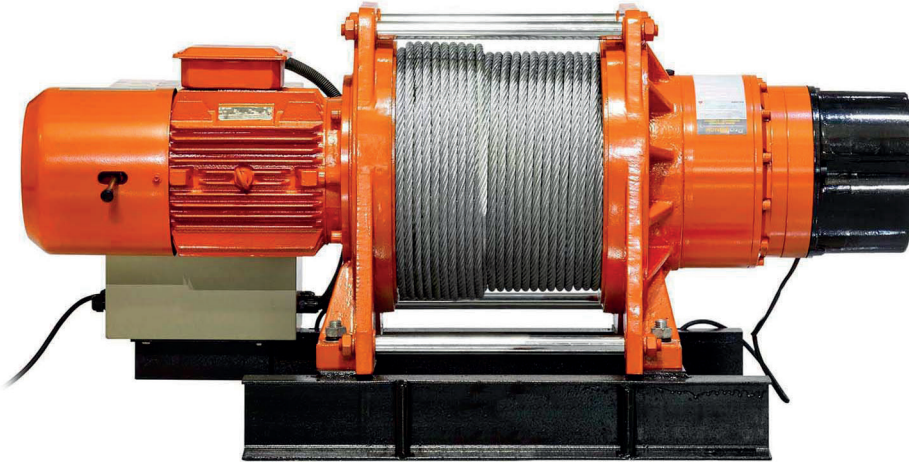

Scale 1:20
Dimension in mm

TECHNICAL PARAMETERS

CODE	PWK4300i
CAPACITY	9.600 Lb
SPEED	35 - 69 Ft / Min
MOTOR	9KW
VOLTAGE	220V/380V/440V/460V 50/60 Hz 3Ph
TOTAL WEIGHT	1200 Lb
STANDARD	ASME B30.7 / B30.10 / ANSI-AWS
WRC ROPE	Ø9/16" x 656 Ft
TOTAL RANGE	646 Ft
ELECTROMAGNETIC BRAKE	Double disc direct on reductor capacity>125%
APPLICATION	Lifting & Pulling

SERVICE FACTOR

SERVICE	LOAD	TIME	MAINTENANCE
NORMAL	<65%	<25%	6 ~ 12
HEAVY	>65%	>25%	3 ~ 6
SEVERE	<100%	Duty cliche limit	1 ~ 3

WARRANTY:

- 1 Year Included
- 2 Year Extended
- 10 Year Parts Service Availability

PERFORMANCE INCLUDED

LAYER	ROPE ON DRUM Ft	LIFTING x LAYER	SPEED Ft/Min
1	65	9.645	34,9
2	117	8.467	39,7
3	188	7.545	44,6
4	285	6.804	49,4
5	351	6.106	54,3
6	444	5.608	69,1
7	544	6.256	69,1
8	833	4.406	68,8

PERFORMANCE OPTIONAL

LAYER	ROPE ON DRUM Ft	LIFTING x LAYER	SPEED Ft/Min
1	41	9.645	34,9
2	90	8.131	41,3
3	146	7.028	47,8
4	210	6.188	54,3
5	261	5.528	60,8
6	261	4.995	67,3

VOLTAGES AVAILABLE

COUNTRY	TRIPHASE
ARGENTINA	380V 50HZ
CHILE	380V 50HZ
COLOMBIA	220V60Hz / 440V60Hz
COSTA RICA	220V60Hz / 440V60Hz
MEXICO	220V60Hz / 440V60Hz
PERU	220V60Hz / 440V60Hz
USA	220V60Hz / 440V60Hz
REST A.L.	220V60Hz / 440V60Hz



WIRELESS CONTROL



CONTROL PANEL



CONTROLLER

* Check for options

N°	DESCRIPTION
1	M8X20 Cylindrical Hex Bolt
2	Protective cover
3	M12 Hex Nut
4	Main disk
5	Spring Ø20x25 Ø2.6X
6	Substitute disk
7	Brake disc
8	Steel brake disc
9	Double end bolt
10	Hexagonal cylindrical bolt M10x30
11	Brake support disc
12	Segers Ø34 lock
13	Hexagonal cylindrical bolt
14	Disc shaft
15	Oil seal Ø55 x 8 Ø35X
16	Bearing disc
17	Bearing
18	Key
19	Triple axle
20	Planetary pinion
21	Retaining ring Ø55
22	Planetary pinion
23	Sprocket 6006
24	Planetary pinion

N°	DESCRIPTION
23	Golilla Ø 25
24	Planetary frame
25	Lock rings Ø 25
26	Round nut M25
27	Hexagonal cylinder bolt M10 x 140
28	Ring terminal pad
29	Ø 65 Golilla damping
30	Bearing 6206
31	Two-level planetary pinion
32	Two Level Planetary Wheel Carrier
33	Two-level planetary shaft
34	Pinion
35	Thick golilla
36	Three-tier planetary frame
37	Ø 40 axial damping elastic ring
38	Bearing 6008 and 6017
39	Fluted housing
40	Oil seal 35x8 Ø55K
41	22x80 key
42	Second / third internal sprocket
43	Hex nut
44	Gearbox reduction bearing
45	Pitman axle
46	

49	Oil seal Ø 85x155 Ø 120X
50	Flat, cross and recessed bolt
51	Cable fixing plant
52	Cable module
53	Sprocket 6021
54	Motor bearing
55	Motor shaft
56	Coupling
57	Key
58	Y132-4 Engine
59	Hex bolt
60	Electric cabinet
61	Control box
62	Electricity cable
63	Chassis
64	Steel cable with hook

PWK4300i PART LIST

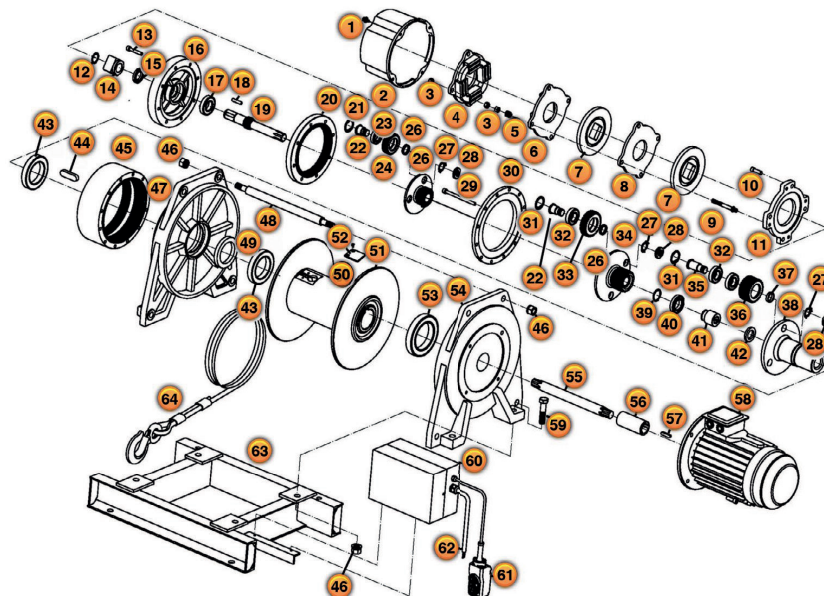

TECHNICAL PARAMETERS

PWG7700i

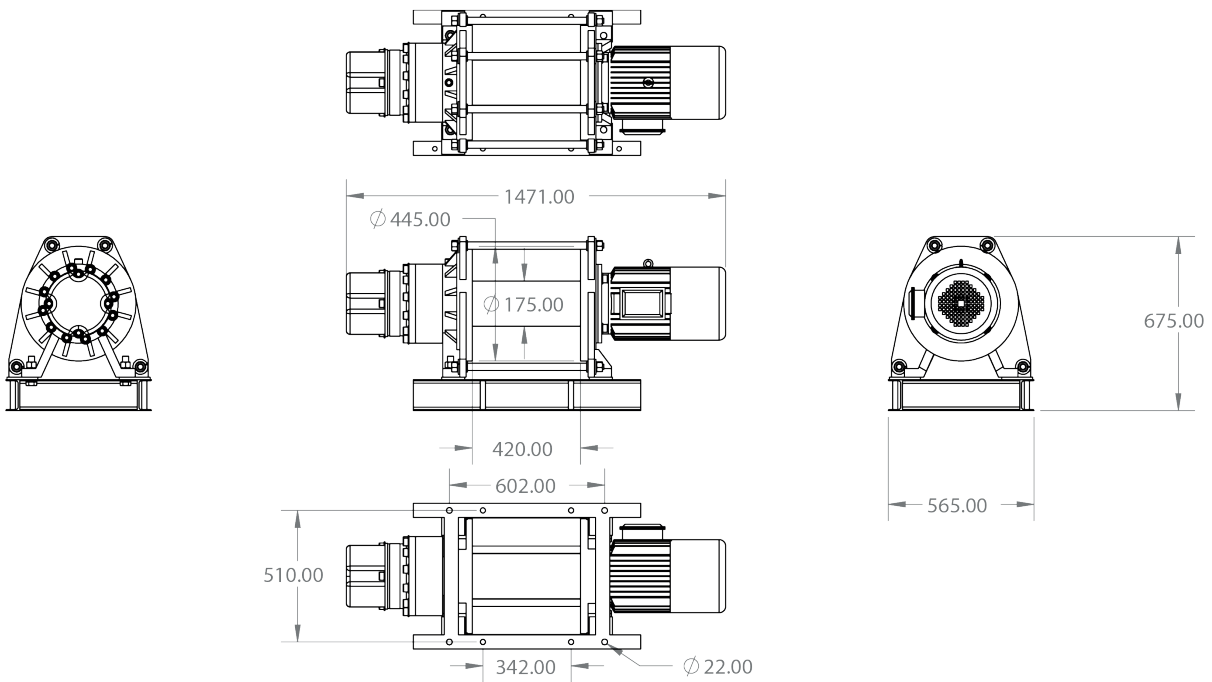
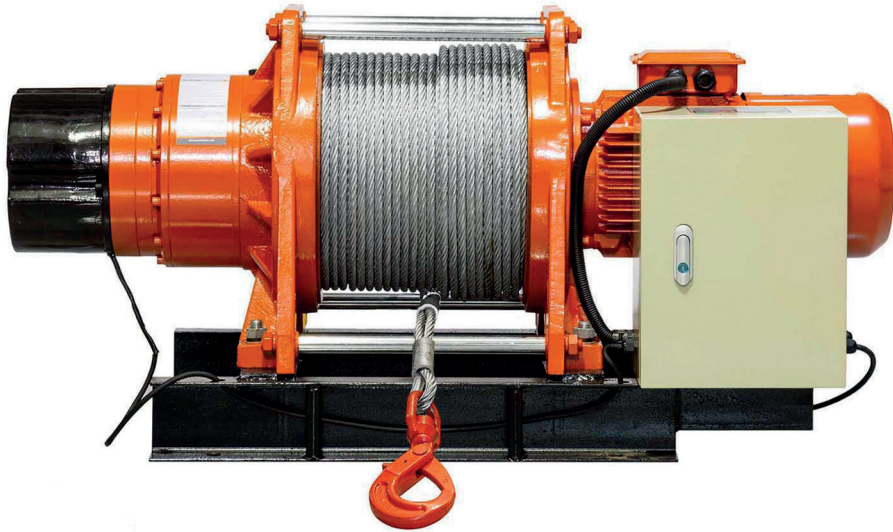

Scale 1:20
Dimension in mm

TECHNICAL PARAMETERS

CODE	PWG7700i
CAPACITY	16.975 Lb
SPEED	33 - 61 Ft / Min
MOTOR	9KW
VOLTAGE	220V/380V/440V/460V 50/60 Hz 3Ph
TOTAL WEIGHT	992 Lb
STANDARD	ASME B30.7 / B30.10 / ANSI-AWS
WRC ROPE	Ø9/16" x 656 Ft
TOTAL RANGE	646 Ft
ELECTROMAGNETIC BRAKE	Double disc direct on reductor capacity>125%
APPLICATION	Lifting & Pulling

SERVICE FACTOR

SERVICE	LOAD	TIME	MAINTENANCE
NORMAL	<65%	<25%	6 ~ 12
HEAVY	>65%	>25%	3 ~ 6
SEVERE	<100%	Duty cliche limit	1 ~ 3

WARRANTY:

- 1 Year Included
- 2 Year Extended
- 10 Year Parts Service Availability

PERFORMANCE INCLUDED

LAYER	ROPE ON DRUM Ft	LIFTING x LAYER	SPEED Ft/Min
1	82	16.976	33,2
2	177	14.846	37,9
3	283	12.191	42,7
4	400	11.668	47,4
5	530	10.748	52,2
6	672	9.665	56,9
7	825	9.123	61,7

PERFORMANCE OPTIONAL

LAYER	ROPE ON DRUM Ft	LIFTING x LAYER	SPEED Ft/Min
1	96	16.976	33,2
2	904	15.119	37,2
3	324	13.629	41,3
4	456	12.406	45,4
5	598	11.385	49,4
6	755	10.519	53,6
7	922	9.775	57,6
8	1.101	9.130	61,7

VOLTAGES AVAILABLE

COUNTRY	TRIPHASE
ARGENTINA	380V 50HZ
CHILE	380V 50HZ
COLOMBIA	220V60Hz / 440V60Hz
COSTA RICA	220V60Hz / 440V60Hz
MEXICO	220V60Hz / 440V60Hz
PERU	220V60Hz / 440V60Hz
USA	220V60Hz / 440V60Hz
REST A.L.	220V60Hz / 440V60Hz



WIRELESS CONTROL



CONTROL PANEL



CONTROLLER

* Check for options

N°	DESCRIPTION
1	M8X20 Cylindrical Hex Bolt
2	Protective cover
3	M12 Hex Nut
4	Main disk
5	Spring Ø20x25 Ø2.6X
6	Substitute disk
7	Brake disc
8	Steel brake disc
9	Double end bolt
10	Hexagonal cylindrical bolt M10x30
11	Brake support disc
12	Segers Ø34 lock
13	Hexagonal cylindrical bolt
14	Disc shaft
15	Oil seal Ø55 x 8 Ø35X
16	Bearing disc
17	Bearing
18	Key
19	Triple axle
20	Planetary pinion
21	Retaining ring Ø55
22	Planetary pinion
23	Sprocket 6006
24	Planetary pinion

N°	DESCRIPTION
23	Golilla Ø 25
24	Planetary frame
25	Lock rings Ø 25
26	Round nut M25
27	Hexagonal cylinder bolt M10 x 140
28	Ring terminal pad
29	Ø 65 Golilla damping
30	Bearing 6206
31	Two-level planetary pinion
32	Two Level Planetary Wheel Carrier
33	Two-level planetary shaft
34	Pinion
35	Thick golilla
36	Three-tier planetary frame
37	Ø 40 axial damping elastic ring
38	Bearing 6008 and 6017
39	Fluted housing
40	Oil seal 35x8 Ø55K
41	22x80 key
42	Second / third internal sprocket
43	Hex nut
44	Gearbox reduction bearing
45	Pitman axle
46	

49	Oil seal Ø 85x155 Ø 120X
50	Flat, cross and recessed bolt
51	Cable fixing plant
52	Cable module
53	Sprocket 6021
54	Motor bearing
55	Motor shaft
56	Coupling
57	Key
58	Y132-4 Engine
59	Hex bolt
60	Electric cabinet
61	Control box
62	Electricity cable
63	Chassis
64	Steel cable with hook

PWG7700i PART LIST

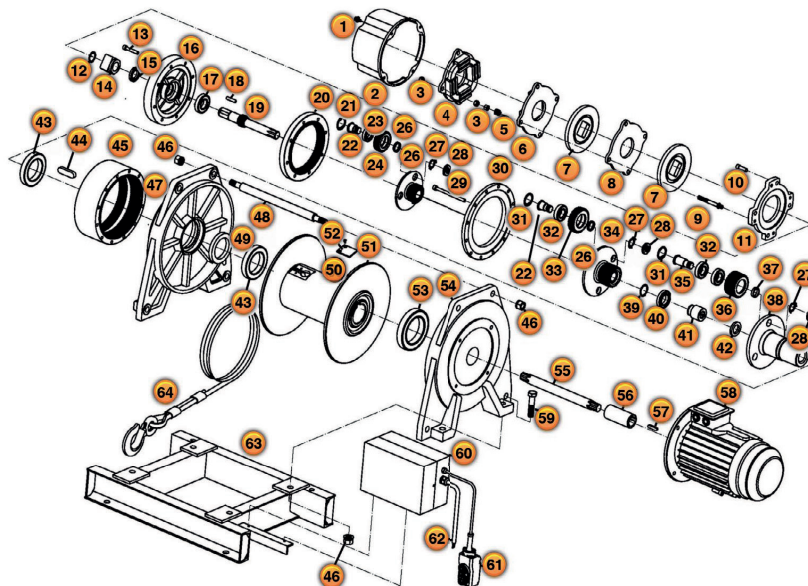

TECHNICAL PARAMETERS

PWK12600i

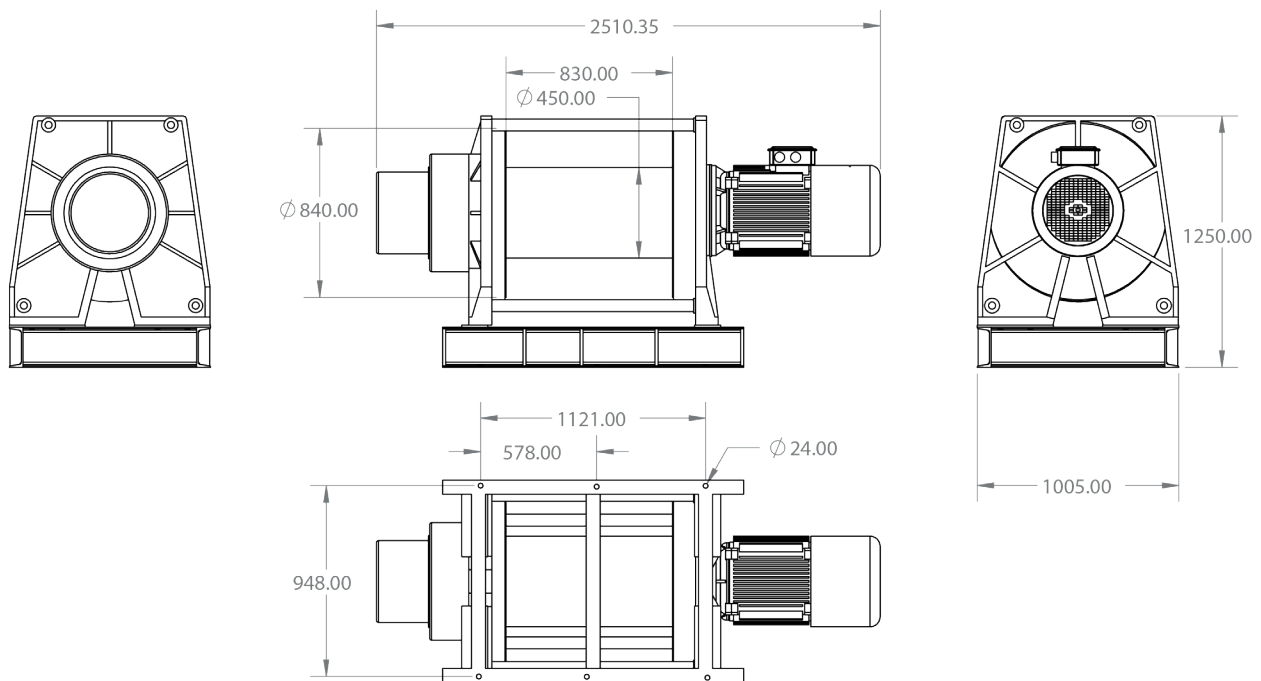
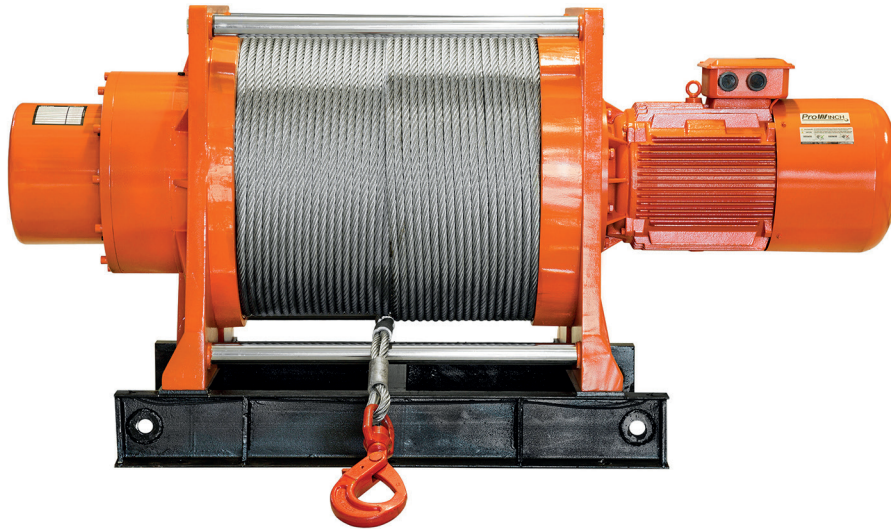

Scale 1:20
Dimension in mm

TECHNICAL PARAMETERS

CODE	PWK12600i
CAPACITY	27.500 Lb
SPEED	30 - 43 Ft / Min
MOTOR	22KW
VOLTAGE	380V/440V/460V 50/60 Hz 3Ph
TOTAL WEIGHT	6.600 Lb
STANDARD	ASME B30.7 / B30.10 / ANSI-AWS
WRC ROPE	Ø1 1/4" x 820 Ft
TOTAL RANGE	646 Ft
ELECTROMAGNETIC BRAKE	Double disc direct on reductor capacity>125%
APPLICATION	Lifting & Pulling

SERVICE FACTOR

SERVICE	LOAD	TIME	MAINTENANCE
NORMAL	<65%	<25%	6 ~ 12
HEAVY	>65%	>25%	3 ~ 6
SEVERE	<100%	Duty cliche limit	1 ~ 3

WARRANTY:

- 1 Year Included
- 2 Year Extended
- 10 Year Parts Service Availability

PERFORMANCE INCLUDED

LAYER	ROPE ON DRUM Ft	LIFTING x LAYER	SPEED Ft/Min
1	130	27.000	29,9
2	274	24.000	33,2
3	434	22.627	36,7
4	609	20.647	40,3
5	769	12.001	43,6

PERFORMANCE OPTIONAL

LAYER	ROPE ON DRUM Ft	LIFTING x LAYER	SPEED Ft/Min
1	162	27.499	29,8
2	336	25.518	38,3
3	3330	23.510	38,3
4	737	21.790	38,1
5	309	20.314	40,9
6	1.190	19.022	43,6
7	1.440	17.893	46,3

VOLTAGES AVAILABLE

COUNTRY	TRIPHASE
ARGENTINA	380V 50HZ
CHILE	380V 50HZ
COLOMBIA	220V60Hz / 440V60Hz
COSTA RICA	220V60Hz / 440V60Hz
MEXICO	220V60Hz / 440V60Hz
PERU	220V60Hz / 440V60Hz
USA	220V60Hz / 440V60Hz
REST A.L.	220V60Hz / 440V60Hz

* Check for options



WIRELESS CONTROL



CONTROL PANEL



CONTROLLER

N°	DESCRIPTION	Q
1	Squirrel cage motor with built-in brake	1
2	Sleeve	1
3	Support base engine side	1
4	Bar	4
5	Bearing	1
6	Bearing	2
7	Segers Lock	2
8	Drum	1
9	Hex bolt	2
10	Cable Lock	1
11	Transmission Shaft	1
12	Reducer side support base	1
13	Retainer	1
14	Bearing	1
15	Key	2
16	3rd level plate	1
17	Round nut	9
18	Flat golilla	3
19	Bearing	3
20	3rd level pinion	3
21	Segers lock	3
22	Planetary shaft 3rd level	3
23	Fluted gasket	1
24		1

N°	DESCRIPTION	Q
25	Bearing	
26	Segers Lock	
27	2nd level plate	
28	Flat golilla	
29	Planetary gear 2nd level	
30	Bearing	
31	Segers Lock	
32	Planetary axis 2nd level	
33	Dish 2nd level minor	
34	1st level axis	
35	Key	
36	Bearing	
37	Retainer	
38	Flat golilla	
39	Pinion	
40	Bearing	
41	Segers Lock	
42	Planetary shaft 1st level	
43	Planetarium 2nd and 3rd level	
44	End plate	
45	Golilla pressure	
46	Hexagonal cylindrical bolt	
47	Planetarium 1st level	
48		

PWK12600i PART LIST

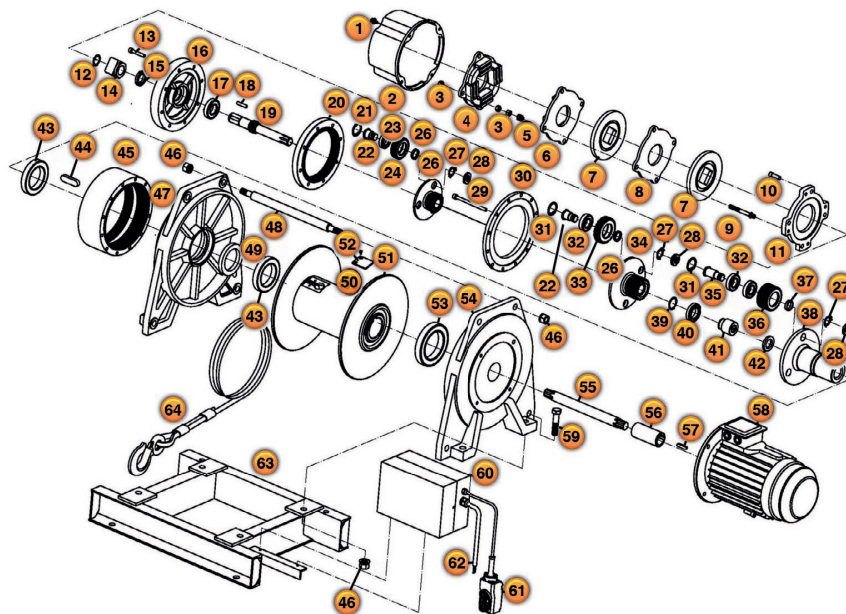

TECHNICAL PARAMETERS

PWK21000

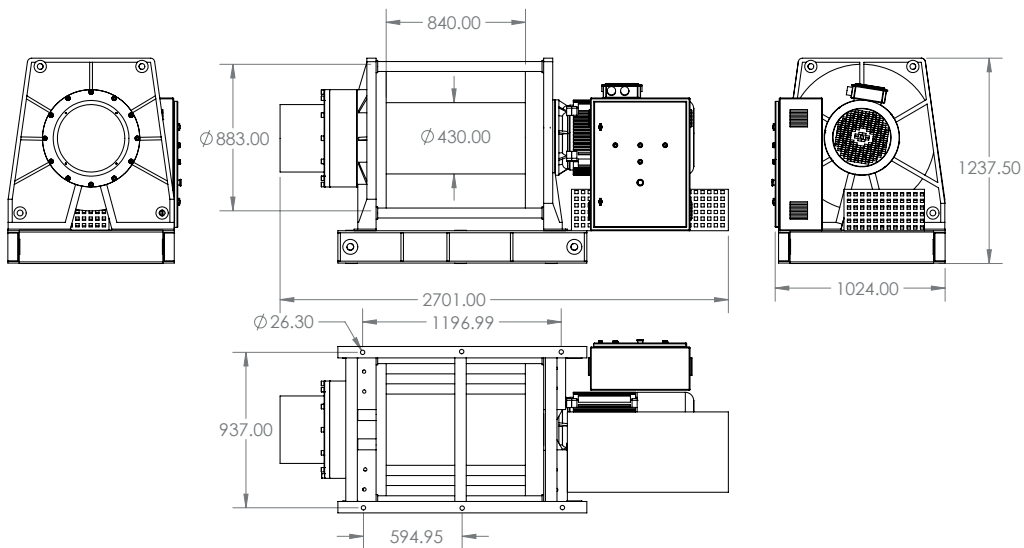
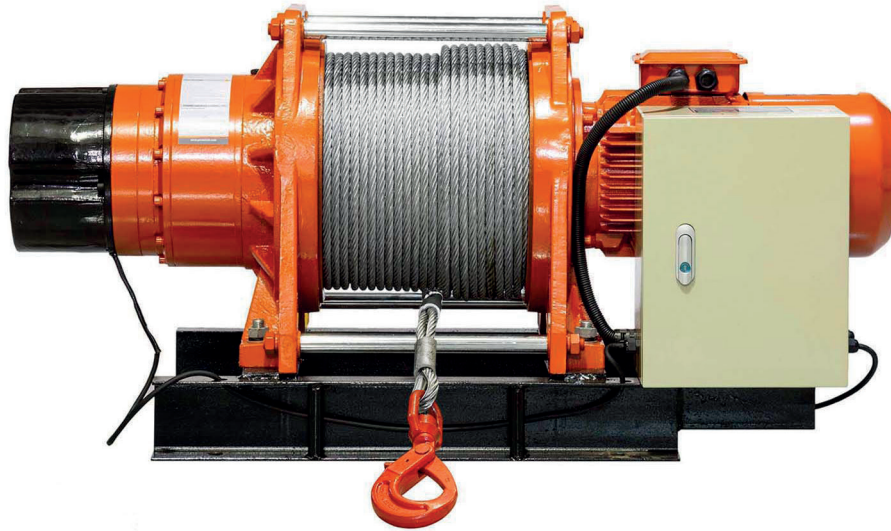

Scale 1:25
Dimension in mm

N°	DESCRIPTION
1	Induction Motor
2	Sleeve
3	Motor Bearing
4	Pitman Shaft
5	Bearing
6	Bearing
7	Hole elastic collar
8	Drum
9	Inner hexagonal sunk screw
10	Rope Module
11	Spline housing
12	Reduction gearbox bearing
13	Oil seal
14	Bearing
15	Flat key
16	Three-level planet frame
17	Round nut
18	Washer I
19	Bearing
20	Three-level gear
21	Hole elastic collar
22	Three-level planet axle
23	Joint spline housing
24	Bearing

N°	DESCRIPTION
23	Axle elastic collar
24	Two-level planet wheel carrier
25	Washer II
26	Two-level planet frame
27	Washer II
28	Two-level planet frame
29	Two level planet shaft
30	Bearing
31	Hole elastic collar
32	Two-level planet frame
33	One-level annular gear
34	Flat key
35	Bearing
36	Oil seal
37	Washer III
38	One-level planet frame
39	Bearing
40	Hole elastic collar
41	One-level planet gear
42	Two-three inner gear
43	Ring terminal pad
44	Spring washer
45	Hexagonal cylindrical screw

46	One level planet gear
47	Bearing disk
48	Hexagonal cylindrical screw
49	Braking diamonds
50	Axle elastic collar
51	Friction disk
52	Double ended bolt
53	Steel friction disk
54	Deputy disk
55	Spring
56	Main disk
57	Hexagon nut
58	Protecting hood
59	Spring washer
60	Hexagonal cylindrical screw
61	Label
62	Hexagonal bolt
63	Spring washer
64	Joint bolt
65	Floor frame
66	Spring Washer
67	Hexagon nut

PWK21000 PART LIST

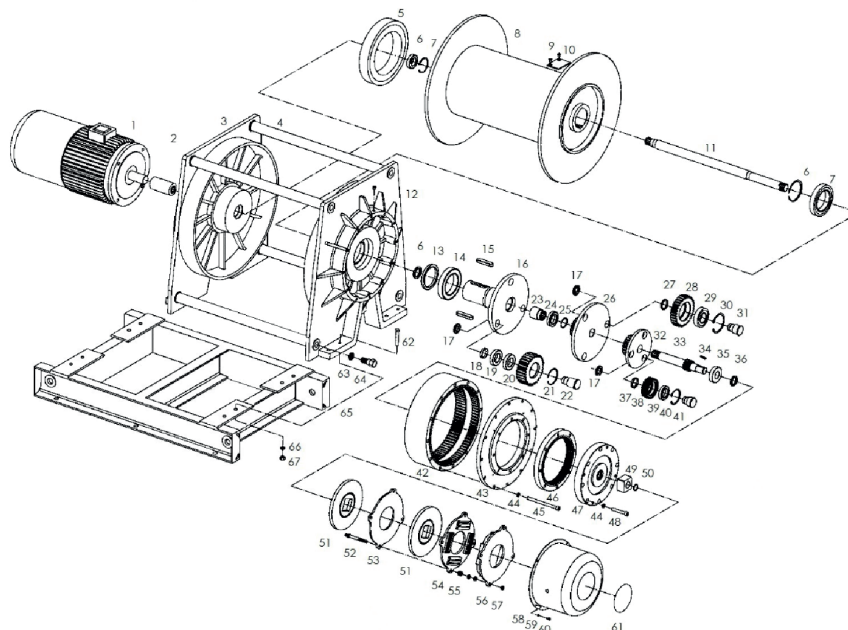

TECHNICAL PARAMETERS

PWK21000XL

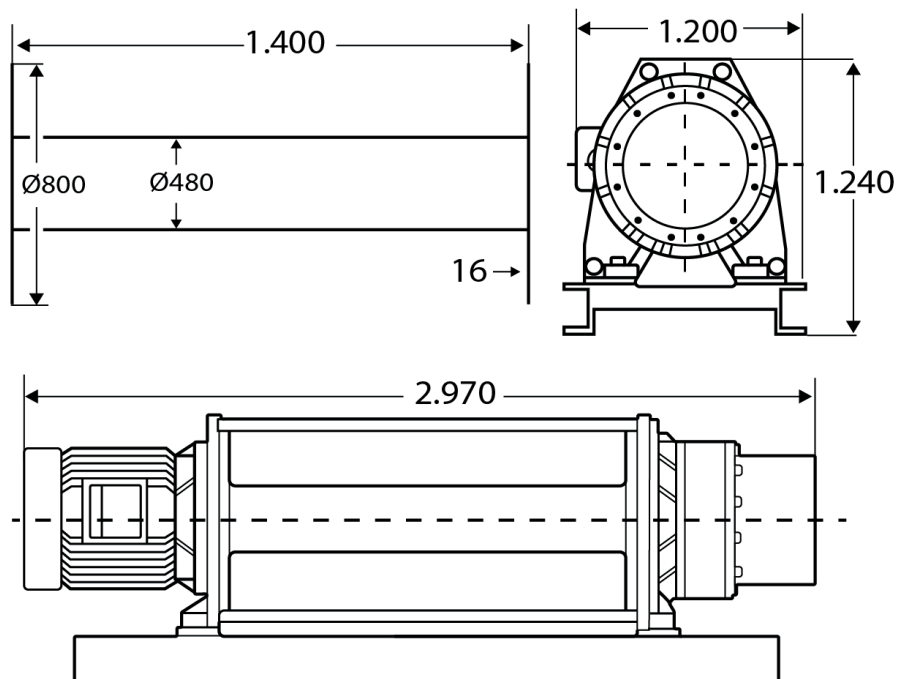

Dimensions in mm / Dimensiones en mm

TECHNICAL PARAMETERS

CODE	PWK21000XL
CAPACITY	28.660 Lb
SPEED	24,7 ~ 38,7~ Ft / Min
MOTOR	30KW
VOLTAGE	380V/440V/460V 50/60 Hz 3Ph
TOTAL WEIGHT	7.275 Lb
STANDARD	ASME B30.7 / B30.10 / ANSI-AWS
WRC ROPE	Ø7/8" x 3.280,8 Ft
TOTAL RANGE	646 Ft
ELECTROMAGNETIC BRAKE	Double disc direct on reductor capacity>125%
APPLICATION	Lifting & Pulling

SERVICE FACTOR

SERVICE	LOAD	TIME	MAINTENANCE
NORMAL	<65%	<25%	6 ~ 12
HEAVY	>65%	>25%	3 ~ 6
SEVERE	<100%	Duty cicle limit	1 ~ 3

WARRANTY:

- 1 Year Included
- 2 Year Extended
- 10 Year Parts Service Availability

PERFORMANCE INCLUDED

LAYER	ROPE ON DRUM Ft	LIFTING x LAYER	SPEED Ft/Min
1	312	46.297	24,7
2	649	42.805	26,7
3	1.012	39.803	28,7
4	1.401	37.194	30,7
5	1.815	34.906	32,7
6	2.254	32.883	34,7
7	2.719	31.082	36,7
8	3.209	29.468	38,7

PERFORMANCE OPTIONAL

LAYER	ROPE ON DRUM Ft	LIFTING x LAYER	SPEED Ft/Min
1	95	21.000	7,5
2	198	19.416	8,1
3	309	18.054	8,7
4	427	16.871	9,4
5	553	15.833	10,0
6	687	14.916	10,6
7	829	14.099	11,2
8	978	13.366	11,8

VOLTAGES AVAILABLE

COUNTRY	TRIPHASE
ARGENTINA	380V 50HZ
CHILE	380V 50HZ
COLOMBIA	220V60Hz / 440V60Hz
COSTA RICA	220V60Hz / 440V60Hz
MEXICO	220V60Hz / 440V60Hz
PERU	220V60Hz / 440V60Hz
USA	220V60Hz / 440V60Hz
REST A.L.	220V60Hz / 440V60Hz



WIRELESS CONTROL



CONTROLLER

* Check for options

N°	DESCRIPTION
1	Induction Motor
2	Sleeve
3	Motor Bearing
4	Pitman Shaft
5	Bearing
6	Bearing
7	Hole elastic collar
8	Drum
9	Inner hexagonal sunk screw
10	Rope Module
11	Spline housing
12	Reduction gearbox bearing
13	Oil seal
14	Bearing
15	Flat key
16	Three-level planet frame
17	Round nut
18	Washer I
19	Bearing
20	Three-level gear
21	Hole elastic collar
22	Three-level planet axle
23	Joint spline housing
24	Bearing

N°	DESCRIPTION
23	Axle elastic collar
24	Two-level planet wheel carttier
25	Washer II
26	Two-level planet frame
27	Washer II
28	Two-level planet frame
29	Two level planet shaft
30	Bearing
31	Hole elastic collar
32	Two-level planet frame
33	One-level annular gear
34	Flat key
35	Bearing
36	Oil seal
37	Washer III
38	One-level planet frame
39	Bearing
40	Hole elastic collar
41	One-level planet gear
42	Two-three inner gear
43	Ring terminal pad
44	Spring washer
45	Hexagonal cylindrical screw

46	One level planet gear
47	Bearing disk
48	Hexagonal cylindrical screw
49	Braking diamonds
50	Axle elastic collar
51	Friction disk
52	Double ended bolt
53	Steel friction disk
54	Deputy disk
55	Spring
56	Main disk
57	Hexagon nut
58	Protecting hood
59	Spring washer
60	Hexagonal cylindrical screw
61	Label
62	Hexagonal bolt
63	Spring washer
64	Joint bolt
65	Floor frame
66	Spring Washer
67	Hexagon nut

PWK21000XL PART LIST

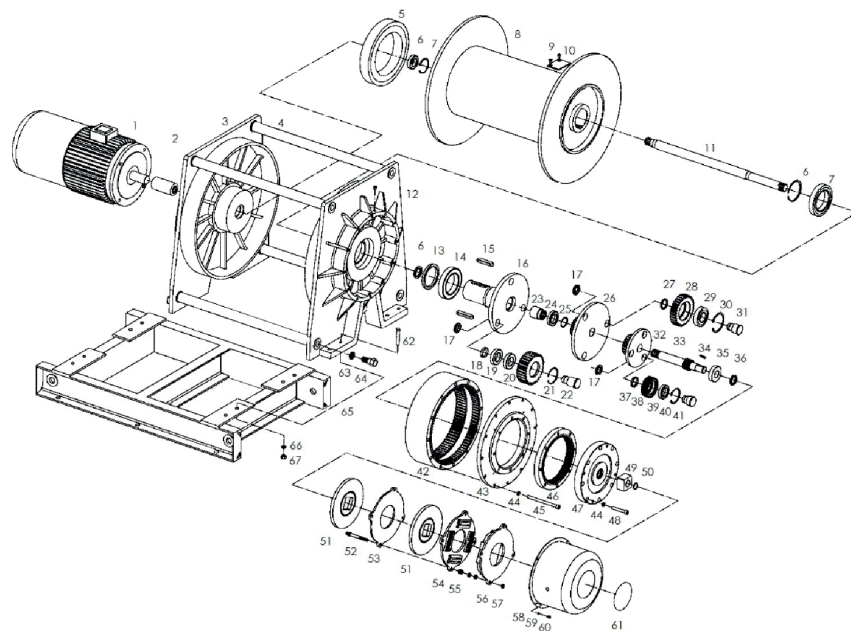

TECHNICAL PARAMETERS PWG23700i

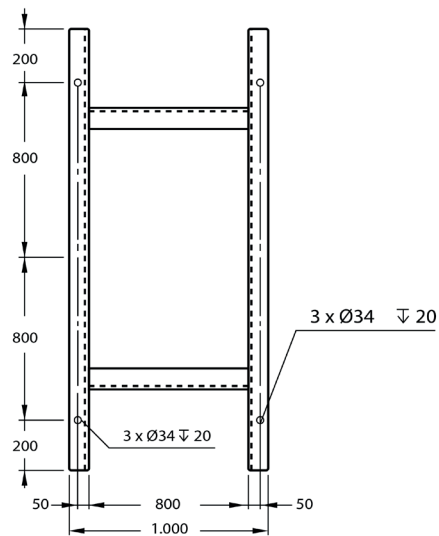
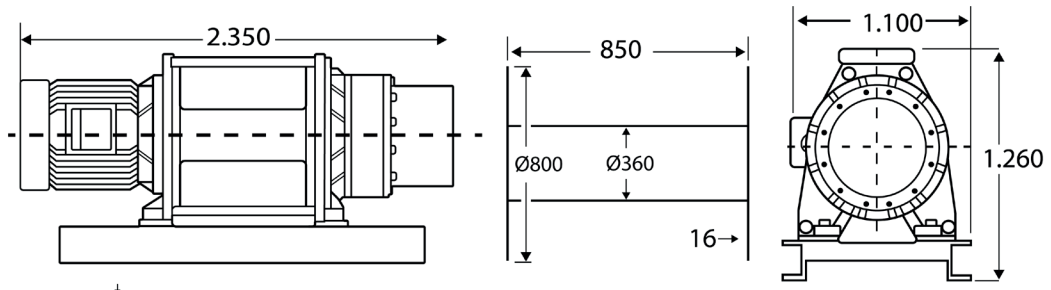

Dimension in mm

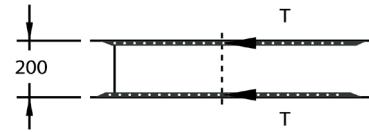
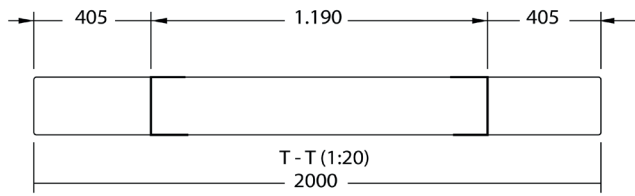

TECHNICAL PARAMETERS

CODE	PWG23700
CAPACITY	52.250 Lb
SPEED	21,3 - 37,8 Ft / Min
MOTOR	40HP
VOLTAGE	380V/440V/460V 50/60 Hz 3Ph
TOTAL WEIGHT	5.687 Lb
STANDARD	ASME B30.7 / B30.10 / ANSI-AWS
WRC ROPE	Ø1 1/4" x 820 Ft
TOTAL RANGE	800 Ft
ELECTROMAGNETIC BRAKE	Double disc direct on reductor capacity>125%
APPLICATION	Lifting & Pulling

WARRANTY:

- 1 Year Included
- 2 Year Extended
- 10 Year Parts Service Availability

PERFORMANCE INCLUDED

RR-W-410E 7/6x196x25 EIPS Fiber Core
 Rope Diameter = 1 1/4 Inch
 Nominal Strength = 142.176 Lb
 Rope Wwight x Ft = 2.63 Lb

LAYER	ROPE ON DRUM Ft	LIFTING x LAYER	SPEED Ft/Min
1	90	52.250	21,3
2	214	45.225	24,6
3	345	39.665	27,9
4	491	35.641	31,2
5	652	32.227	34,5
6	829	29.409	37,8

PERFORMANCE OPTIONAL

RR-W-410E 7/6x196x25 EIPS Fiber Core
 Rope Diameter = 1 3/8 Inch
 Nominal Strength = 195.987 Lb
 Rope Wwight x Ft = 3.49 Lb

LAYER	ROPE ON DRUM Ft	LIFTING x LAYER	SPEED Ft/Min
1	90	52.250	21,3
2	196	44.601	24,9
3	317	38.905	28,5
4	453	34.500	32,2
5	605	30.990	35,8
6	772	28.129	39,5

PERFORMANCE OPTIONAL

RR-W-410E 7/6x196x25 EIPS Fiber Core

Rope Diameter = 1 1/4 Inch

Nominal Strength = 142.176 Lb

Rope Wwight x Ft = 2.63 Lb

LAYER	ROPE ON DRUM Ft	LIFTING x LAYER	SPEED Ft/Min
1	124	52.250	21,3
2	264	46.406	23,9
3	419	41.836	25,5
4	589	38.045	29,2
5	775	34.883	31,6
6	977	32.207	34,5
7	1.194	29.912	37,1
8	1.426	27.923	39,8
9	1.674	26,181	42,4

SERVICE FACTOR

SERVICE	LOAD	TIME	MAINTENANCE
NORMAL	<65%	<25%	6 ~ 12
HEAVY	>65%	>25%	3 ~ 6
SEVERE	<100%	Duty cliche limit	1 ~ 3

VOLTAGES AVAILABLE

COUNTRY	TRIPHASE
ARGENTINA	380V 50HZ
CHILE	380V 50HZ
COLOMBIA	220V60Hz / 440V60Hz
COSTA RICA	220V60Hz / 440V60Hz
MEXICO	220V60Hz / 440V60Hz
PERU	220V60Hz / 440V60Hz
USA	220V60Hz / 440V60Hz
REST A.L.	220V60Hz / 440V60Hz

* Check for options



WIRELESS CONTROL



CONTROL PANEL



CONTROLLER

N°	DESCRIPTION
1	Induction Motor
2	Key
3	Hexagonal bold
4	Presion Washer
5	Hexagonal Cap Screw
6	Flat Washer
7	Presion Washer
8	Nut
9	Motor Support
10	Bearing
11	Fixation Drum Plate
12	Steel cable with hook
13	Drum
14	Conector Axis
15	Transmission Sleeve
16	Oil seal
17	Retainer Ring
18	Bearing
19	Sleeve
20	Transmission rack support
21	Oil Seal
22	Key
23	Out axis
24	Nut

N°	DESCRIPTION
25	Washer
26	Third planetary pinion
27	Third Planetary Gear
28	Bearing
29	Retainer Ring
30	Retainer ring
31	Oil seal
32	Nut
33	Packaging
34	Internal Third Gear
35	Third Axis
36	Nut
37	Washer
38	Second planetary pinion
39	Second Planetary Gear
40	Bearing
41	Retainer Ring
42	Retainer Ring
43	Fixation Plate
44	Presion Washer
45	Hexagonal Screw
46	Second Axis
47	First Planetary Pinion
48	First Planetary Gear

49	Packaging
50	Internal first and second gear
51	Chassis
52	First Axis
53	Key
54	Bearing
55	Break base
56	Perssion Washer
57	Hexagonal Screw
58	Oil Seal
59	Transmission Sleeve
60	Retainer Ring
61	Break groups
62	Back Break Cover
63	Remote Control
64	Low Tension Control
65	Hexagonal Screw

PWG23700 PART LIST

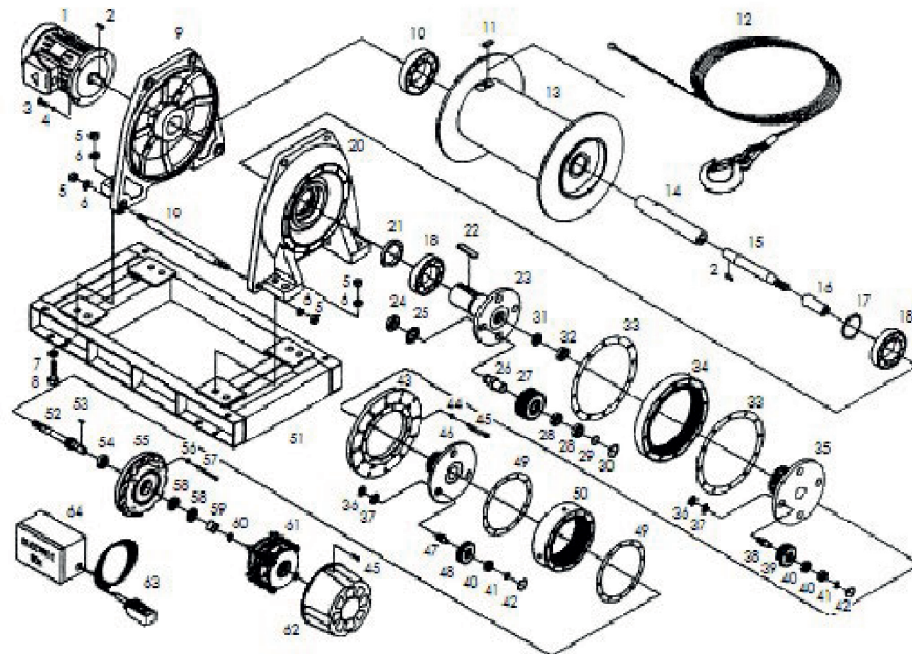

Cranes Service

4022 East Greenway Road,
Suite 11-199, Phoenix, AZ 85032
(602) 321 9751
cranex.services@outlook.com

MIAMI, FL PROWINCH LLC www.prowinch.com

2901 NW 21st Terrace
Miami, FL 33142
United States
+1 (800) 971-8061

Fortis Alloy Mexico S.a. De C.v www.prowinch.mx

Fortis Alloy Mexico, S.A. de C.V. Vicente
Guerrero No. 403 Col. San Miguel,
Apodaca, Nuevo Leon,
Mexico C.P. 66649
+52 (81) 8244-1351

Ayers USA Cranes ayersusa.com

26111 US-90, Robertsdale,
AL 36567
251-929-1773
service@ayersusa.com

Provedora Industrial Y Tecnica, S.a. De C.v. www.pronte.com.sv

Av. Alberto Masferrer Sur, Col.
Campestre No. 211
San Salvador, El Salvador
2264-1100

Guatemala

7a Avenida 1-22 Zona 13,
Pamplona, Ciudad de
Guatemala
+502 2381-8383
ever.mendez@contecindustrial.com

DEZA JACOBS

Av Mansiche 1586, Trujillo,
La Libertad, Peru
51 44 618700
ventas@dezajacobs.com
www.dezajacobs.com

PROWINCH PERÚ

info@prowinch.pe
www.prowinch.pe

Prowinch Colombia Sas www.prowinch.co

Calle 15 No 27-74 Local 8 Barrio
Paloquemao en Bogotá, 111411
Bogotá Colombia
(+57) 601 742 1374

Servicios Ivankovich GAR S.A.

Entrada principal del Colegio Vicente Lachner
100 Norte, 50 Oeste Cartago Costa Rica 7050
+50 625531415
juan@ivankovich.co.cr

Equipos De Izaje Prowinch Chile Spa Www.prowinch.cl

Parque Riesco 3407, Recoleta,
Región Metropolitana, Chile
+56-2-26218989



ProWINCH