

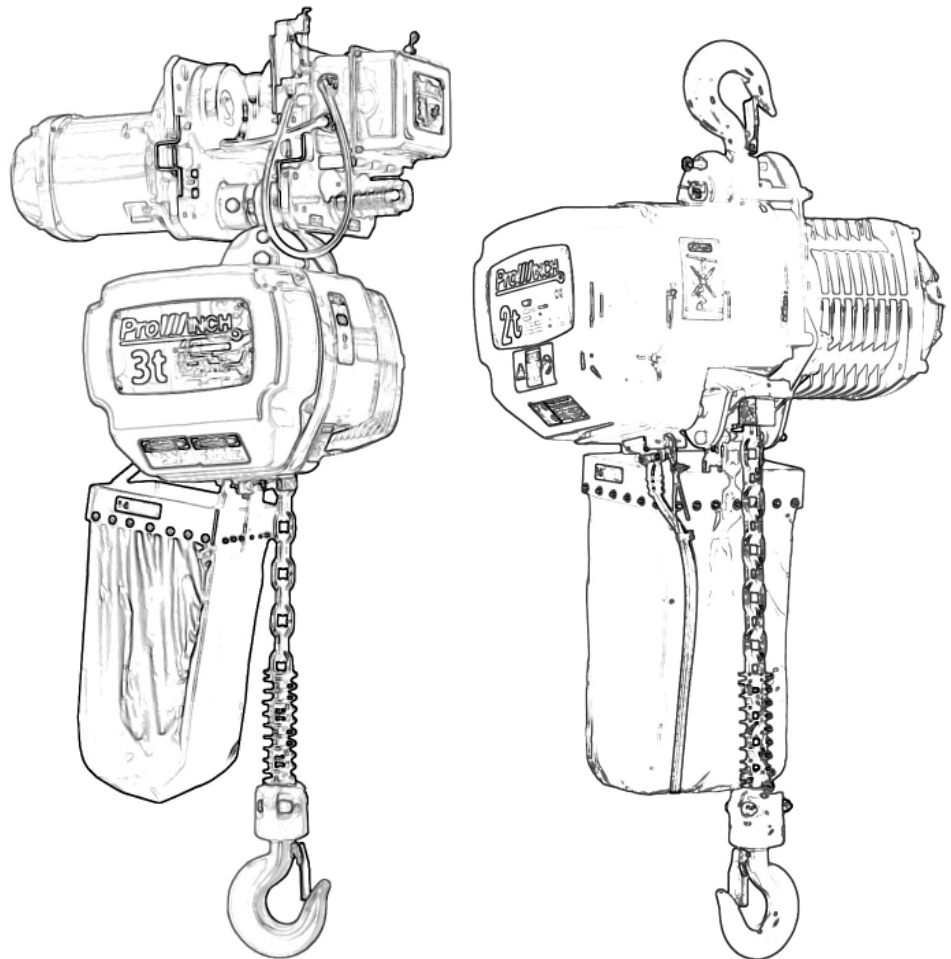

PWR Electric Chain Hoist 1 and 2 Speed

User's Manual / Manual de usuario
Safety Warnings / Advertencias de Seguridad



This page intentionally left blank



PWR05 / PWR05i
1/2 Ton / Electric
Chain Hoist
1 - 2 Speed



PWR1/PWR1i
1 Ton / Electric
Chain Hoist
1 - 2 Speed



PWR2/PWR2i
2 Ton Electric
Chain Hoist
1 - 2 Speed



PWR5/PWR5i
5 Ton Electric
Chain Hoist
1 - 2 Speed



PWR10
10 Ton / Electric
Chain Hoist
1 Speed



PWR20
20 Ton / Electric
Chain Hoist
1 Speed



PWR3/PWR3i
3 Ton Electric
Chain Hoist
1 - 2 Speed



PWRC05 / PWRC05i
1/2 Ton / Electric
Chain Hoist
Power Trolley
1 - 2 Speed



PWRC1/PWRC1i
1 Ton / Electric
Chain Hoist
Power Trolley
1 - 2 Speed



PWR30
30 Ton / Electric
Chain Hoist
1 Speed



PWRC7/PWRC7i
7.5 Ton Electric
Chain Hoist
Power Trolley
1 - 2 Speed



PWRC5/PWRC5i
5 Ton Electric
Chain Hoist
Power Trolley
1 - 2 Speed

**PWRC2/PWRC2i**

2 Ton / Electric
Chain Hoist
Power Trolley
1 - 2 Speed

**PWRC3/PWRC3i**

3 Ton / Electric
Chain Hoist
Power Trolley
1 - 2 Speed

**PWRC10 / PWRC10i**

10 Ton / Electric
Chain Hoist
Power Trolley
1 - 2 Speed

**PWRC20**

20 Ton / Electric
Chain Hoist
Power Trolley
1 Speed



**PWR05M5 /
PWR05M5i**

1/2 Ton / Electric
Chain Hoist
1 - 2 Speed



**PWR1M5 /
PWR1M5i**

1 Ton / Electric
Chain Hoist
1 - 2 Speed



**PWR2M5 /
PWR2M5i**

2 Ton Electric
Chain Hoist
1 - 2 Speed



**PWR3M5 /
PWR3M5i**

3 Ton Electric
Chain Hoist
1 - 2 Speed



**PWR5M5 /
PWR5M5i**

5 Ton Electric
Chain Hoist
1 - 2 Speed



**PWRC05M5 /
PWR05M5i**

1/2 Ton / Electric
Chain Hoist
1 - 2 Speed



**PWRC1M5 /
PWRC1M5i**

1 Ton / Electric
Chain Hoist
1 - 2 Speed



**PWRC2M5 /
PWRC2M5i**

2 Ton Electric
Chain Hoist
1 - 2 Speed



**PWRC3M5 /
PWRC3M5i**

2 Ton Electric
Chain Hoist
1 - 2 Speed



**PWRC5M5 /
PWRC5M5i**

5 Ton / Electric
Chain Hoist
1 - 2 Speed

PROPERTY REGISTRY N° 189487
ANY REPRODUCTION IS FORBIDDEN
PROPERTY OF PROWINCH® 2022 - V.06.24[LA] ALL RIGHTS RESERVED
PROWINCH LLC COMPANY WITH QUALITY MANAGEMENT SYSTEM

PROWINCH® DISCLAIMER

Prowinch® LLC declares that it has made all safety recommendations related to the purchased product to the customer. As a result, it does not assume any responsibility for any damages or losses that the client or third parties may suffer. These can be caused by or as a direct or indirect result of a breach or omission of instructions or safety warnings in the User Manual and Security Warnings provided with the unit purchased. Prowinch® LLC will not be liable for accidents and/or damages to persons and/or property resulting from the negligent use of the product. In no case does Prowinch® LLC assume any liability arising from using these voluntary recommendations and does not offer any guarantee concerning them. These recommendations do not take precedence over the current safety regulations of the plant. For purposes of enforcing the warranty of the product purchased, Prowinch® LLC, will only be liable for any damage when proven the user has followed each one of the warnings contained in the User Manual and Safety.

1. It is the sole responsibility of the Client / User to verify that the acquired equipment, products, and accessories comply with the characteristics, capacities, requirements, components, accessories, and other conditions for the use that the Client/user intends to give it.
2. It is also the sole responsibility of the Client / User to ensure that the equipment and products purchased are operated and maintained with adequate safety standards and by personnel properly trained in their use. The Client / User is also responsible for implementing all security measures necessary to prevent accidents or damages to people or property and for following the indications and warnings of the corresponding manual.
3. Any assistance provided by Prowinch® LLC in selecting the equipment, capacities, and characteristics required by the client is delivered free of charge and based on the information about the application, use, and requirements provided by the client. It is not the responsibility of Prowinch® LLC to verify the accuracy of the given information. It is the sole and exclusive responsibility of the client -or who will use the equipment and products acquired- to ensure that the specifications comply with the capabilities, characteristics, up-to-date maintenance, and everything necessary for a correct and safe operation about the intended use.
4. Prowinch® LLC recommends using winches with four brakes for personnel lifting. The use of winches with three brakes or less, or operating with safety standards less than required for personnel lifting is not recommended.
5. To guarantee the safety of the equipment's operators, it is necessary to conduct inspections and maintenance of the equipment according to the recommended frequency of its work cycle. It is mandatory to keep records and evidence, including written and photographic reports of: Maintenance, Start-up, Load Tests, Training, Certifications, Inspections, and Reports of failures and accidents.
6. The reports mentioned above must be emailed to registros@prowinch.com within the first seven calendar days after an event.
7. Compliance with timely implementation of mandatory activities described in points 6 and 7, in addition to all the activities mentioned in the corresponding guidelines, are the user's sole responsibility. Failure to comply with the preceding conditions releases Prowinch® LLC from any liability. The information contained in this manual may contain technical errors or inaccuracies. Prowinch® LLC is not responsible for errors, omissions, or incorrect information. This manual is subject to change without prior notice. Download the latest version available at www.prowinch.com. Always check www.prowinch.com for the latest information regarding this product.



WARNING

Users of Hoists, Cranes, and other lifting and material-movement equipment must be knowledgeable about their safe and proper use and aware of their responsibilities as outlined in all applicable standards and regulations. The ASME/ANSI B30 Standard contains provisions for the construction, installation, operation, inspection, testing, maintenance, and use of cranes and other lifting and material-movement-related equipment. As OSHA's, ASME, and ANSI standards state, a qualified person shall perform the installation, setup, and operation of these units and equipment. OSHA requires rated load tests for new and altered cranes. OSHA's standard at 29 CFR 1910.179(k) states:

Operational tests.

Before initial use, all new and altered cranes must be tested to ensure compliance with this section, including the following functions:

Hoisting and lowering.

Trolley travel.

Bridge travel.

Limit switches, locking, and safety devices.

The trip setting of hoist limit switches shall be determined by tests with an empty hook traveling at increasing speeds up to the maximum speed. The actuating mechanism of the limit switch shall be located so that it will trip the switch, under all conditions, in sufficient time to prevent contact of the hook or hook block with any part of the trolley.

Rated load test: Test loads shall not be more than 125 percent of the rated load unless otherwise recommended by the manufacturer. Once a rated load test is performed, paragraph 1910.179(k)(2) requires that "[t]he test reports shall be placed on file where readily available to appointed personnel."

To ensure safety and installation requirements, Prowinch requires Load Tests to be performed before initial use for all Hoists, Winches, and Cranes, as well as other related components. Not fulfilling this requirement is dangerous, could lead to equipment failure, and will automatically void the warranty.

**WARNING**

The B30 Standard is intended to:

- (a) Prevent or minimize worker injury, and otherwise provide for protecting life, limb, and property by prescribing safety requirements. (b) Provide direction to manufacturers, owners, employers, users, and others concerned with or responsible for, its application.
- (b) Provide direction to manufacturers, owners, employers, users, and others concerned with, or responsible for, its application.
- (c) Guide governments and other regulatory bodies in developing, promulgating, and enforcing appropriate safety directives. The equipment covered by the B30 Standard is subject to hazards that cannot be abated by mechanical means but only by the exercise of intelligence, care, and common sense. It is therefore essential to have personnel involved in the use and operation of equipment that are competent, careful, physically and mentally qualified, and trained in the proper operation of the equipment and the handling of loads. Serious hazards include, but are not limited to, improper or inadequate maintenance, overloading, dropping, or slipping of the load, obstructing the free passage of the load, and using equipment for a purpose for which it was not intended or designed.

Failure to Read, Understand and Follow the information in the corresponding ASME B30 Standard for your Hoist and Lifting equipment may result in severe INJURY or DEATH. It is YOUR RESPONSIBILITY to consider all risk factors and follow all the equipment related to ASME B30 standards, which comprise the following volumes:

- B30.1 Jacks, Industrial Rollers, Air Casters, and Hydraulic Gantries.
- B30.2 Overhead and Gantry Cranes (Top Running Bridge, Single or Multiple Girder, Top Running Trolley Hoist).
- B30.3 Tower Cranes.
- B30.4 Portal and Pedestal Cranes.
- B30.5 Mobile and Locomotive Cranes.
- B30.6 Derricks.
- B30.7 Winches.
- B30.8 Floating Cranes and Floating Derricks.
- B30.9 Slings.
- B30.10 Hooks.
- B30.11 Monorails and Underhung Cranes.
- B30.12 Handling Loads Suspended From Rotorcraft.
- B30.13 Storage/Retrieval (S/R) Machines and Associated Equipment.
- B30.14 Side Boom Tractors.
- B30.15 Mobile Hydraulic Cranes.
- B30.16 Overhead Hoists (Underhung).



WARNING

B30.17 Overhead and Gantry Cranes (Top Running Bridge, Single Girder, Underhung Hoist).

B30.18 Stacker Cranes (Top or Under Running Bridge, Multiple Girder With Top or Under Running Trolley Hoist).

B30.19 Cableways.

B30.20 Below-the-Hook Lifting Devices.

B30.21 Lever Hoists.

B30.22 Articulating Boom Cranes.

B30.23 Personnel Lifting Systems.

B30.24 Container Cranes.

B30.25 Scrap and Material Handlers. B30.26 Rigging Hardware.

B30.27 Material Placement Systems. B30.28 Balance Lifting Units. B30.29 Self-Erecting Tower Cranes. B30.30 Ropes.

DO NOT



WARNING

1. DO NOT Operate, install, or repair the hoist unless trained and authorized.
2. DO NOT Operate the hoist unless you have first read the operator's manual.
3. DO NOT Operate the hoist without appropriate PPE and without performing a pre-shift inspection.
4. DO NOT Operate the hoist if not complying with all required OSHA regulations.
5. DO NOT Lift more than the rated load.
6. DO NOT Lift people or lift loads over people.
7. DO NOT Wrap the hoisting rope or chain around the load.
8. DO NOT Operate with the chain/rope not properly seated in the sprockets, drum, or sheave.
9. DO NOT Operate unless the direction of the hook travel agrees with the direction shown on the control.
10. DO NOT Operate the hoist unless the hook travel limit devices function properly. (Test without a load PRE-SHIFT)
11. DO NOT Operate the hoist with twisted, kinked, damaged, dirty, or unlubricated chain or rope.
12. DO NOT Operate a damaged or malfunctioning hoist.
13. DO NOT Operate the hoist when the hook is not centered under the hoist
14. DO NOT Remove or obscure this tag or other WARNING & SAFETY LABELS.

DAILY CHECKLIST**WARNING**

TAGGED HOIST: Ensure the crane or hoist is not tagged out of order.

CONTROL DEVICES: Test Run. Ensure all motions agree with control device marking.

BRAKES: Check all motions for excessive drift and abnormal stopping distances.

HOOK: Check for damage, cracks, nicks, gouges, deformations on throat opening, wear on saddle or load-bearing point, and twist.

HOOK LATCH: Check for proper operations.

**WARNING**

WIRE ROPE: Check for broken wires, broken strands, kinks, and deformation or damage to the rope structure.

CHAIN: Check for corrosion, wear, elongation, twist, nicks, or gouges. Keep Chain/Wire Rope Clean and Lubricated.

REEVING: Check the rope for proper reeving and that rope parts are not twisted.

LIMIT SWITCHES: Ensure that all limit devices stop lifting motion before the load block or chain/rope stop strikes the hoist.

OIL LEAKAGE: Check for any signs of oil leakage on the crane/hoist and the floor.

UNUSUAL SOUNDS: Check for unusual sounds from the hoist while operating.

WARNING & SAFETY LABELS: Ensure that labels are not missing and they are legible.

Thank you for purchasing our Prowinch® Electric Chain Hoist. This User Manual provides important information for personnel involved with installation, operation, and maintenance of this product. Read this User Manual before installing, operating, or maintaining product.

1. SAFETY PRECAUTIONS

Prowinch® Electric Chain Hoist is designed for safe and reliable service if operated according to this User Manual.

Respect all warnings for personal and third-party safety. The inadequate operation of this equipment may cause injuries or damage to the equipment.

Read and understand this User Manual carefully before installation and commission of equipment. Always keep this User Manual in an accessible location.

With compact structure, lightweight, and ease of use, PWR and PRWC models are preferred hoists for daily use in factories, mines, seaports, and warehouses.

Hoists misused may harm users and result in wounds, injuries, or death. This User Manual highlights symbols and notes for caution, warning, and danger. Attention to these areas ensures the safety of the operator.



Hard Hat



Safety Glasses



Safety Gloves



Safety Shoes

Safety Precautions



WARNING:

This symbol indicates a dangerous situation which if not avoided may cause minor or moderate injury. It is also used for indicating unsafe practices.



DANGER:

This symbol indicates a potentially dangerous situation which if not avoided may cause severe injuries or death

 WARNING DO NOT stand under the load ADVERTENCIA NO ubicarse bajo la carga <small>ProWINCH</small>	 WARNING Crush hazard ADVERTENCIA Peligro de atrapamiento <small>ProWINCH</small>	WARNING Verify torque, tighten bases periodically ADVERTENCIA Verificar torque, apriete bases periódicamente <small>ProWINCH</small>
---------------------------------------------------------------------------------------------------------------------------------	----------------------------------------------------------------------------------------------------------------	----------------------------------------------------------------------------------------------------------------------------------------------------------------

Read and understand the contents of this User Manual thoroughly before handling the product. Practicing correct and safe operating procedures and implementing the recommended preventative maintenance will ensure a long, reliable, and safe service. After carefully reading and understanding this User Manual, store it for future reference.



DANGER

All operators and other users who are near the steel chain or its load must wear required safety equipment: gloves, safety helmet / hard hat, safety shoes and eye protection.



WARNING

Before installing, removing, inspecting, or performing any maintenance on the hoist, the unit must be unplugged, locked out, and tagged out. Do not use this equipment in hazardous locations.

Before using equipment:

- Read and understand the instructions in this User Manual and labels associated with hoist before operating equipment.
- Wear appropriate clothing: Do not wear jewelry or loose clothes as they may attach to chain or hook.
- Wear leather gloves.
- Wear non-slippery safety shoes, helmet, and eye protection.
- Perform full check of hoist. Check for damaged parts or unusual characteristics.
- Keep a safe distance: suggested distance is at least 1.5 times the length of hoist's chain. Broken or loose chain may cause injuries or death.
- Check hoist and chain are properly lubricated.
- Secure electric chain hoist to a suitable support.
- Visually inspect all electric chain hoists in addition to regular and maintenance inspections

During Operation:**ALWAYS**

- Refer to maximum load capacity displayed on ID plate of hoist, not capacity of hook.
- Stop operation immediately if unauthorized personnel enter working area.
- Check state of hoist: If engine overheats, stop hoist and let it cool for a while.
- Stop, check, and secure load if hoist stops or loses movement during operation.
- Focus on operation. Always pay attention and keep proper balance.
- Unplug hoist after operation.

NEVER

- Exceed maximum load capacity.
- Operate damaged or malfunctioning hoist.
- Operate hoist if behaving unusually.
- Lift, support, transport people, or lift or support loads over people.
- Walk over chain.
- Operate electric chain hoist with twisted, kinked, damaged or worn load chain.
- Use load chain as a sling around load.
- Operate a hoist if ID plate or safety labels are missing or illegible.
- Operate electric chain hoist when exposed to rain or water.
- Use if operator is sick or not completely attentive.

- Leave hoist unattended if energized or loaded.
- Operate hoist unless load is centered.
- Operate beyond limits of load chain or extend chain.
- Use load chain or hook as an electrical or welding ground.
- Remove labels on electric chain hoist.
- Use hoist to lift load at an angle, nor pull or drag load

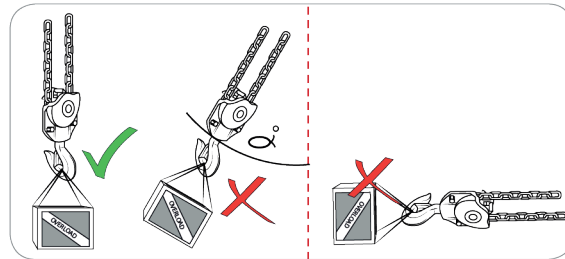

Inspection, Maintenance and Repairs:

- Only trained and authorized personnel may conduct repairs to equipment.
- Use only original Prowinch® parts. The use of any other part immediately voids warranty.
- Failure to use only original Prowinch® parts may endanger operator.

ALWAYS

- Check quality of electrical connections.
- Check chain and maintain lubrication.
- Prevent others from being beneath load.
- Regularly inspect and maintain hoist.
- Check correct installation of hoist before using.
- Avoid contact with explosive gases or materials.

NEVER

- Overload equipment
- Transport people or animals.
- Stand below load.
- Use hoist if exposed to rain, snow, or electrical storm.
- Leave load suspended for extended period. This may cause component deformation an accident.
- Exceed designated operating temperatures stated in this User Manual (differ depending on model).
- Expose hoist to water, sand, corrosive environment, or other substances which may damage equipment.

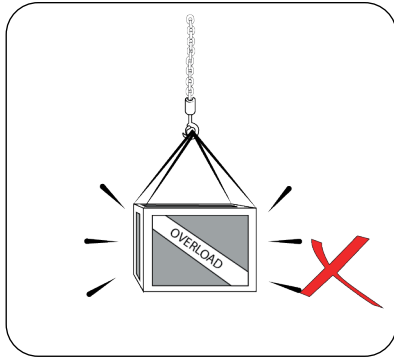

1. Do not overload

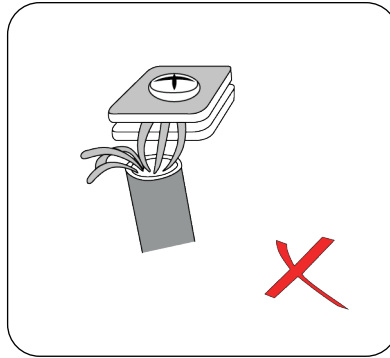

2. Check the quality of the electrical

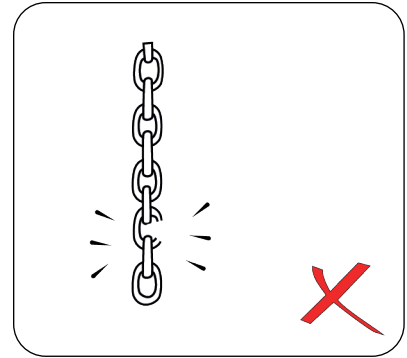

3. Periodically check the chain and keep it lubricated.

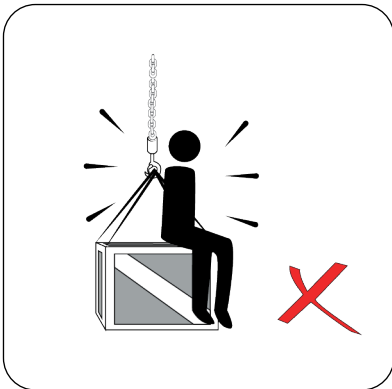

4. Do not transport people or animals.

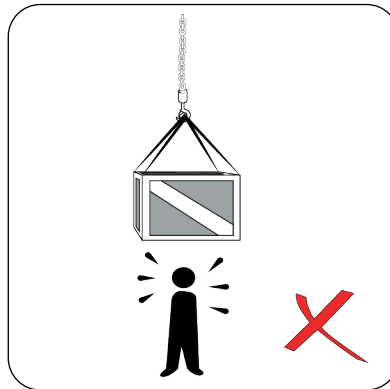

5. Do not place under load and prevent others from doing so.

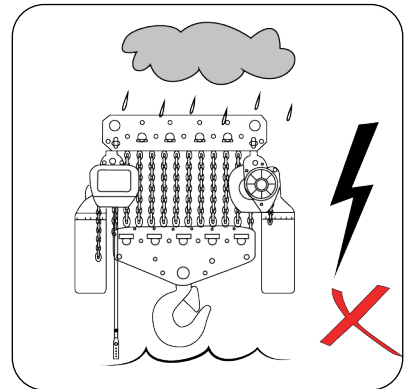

6. Do not use hoist if exposed to rain, snow or lightning.

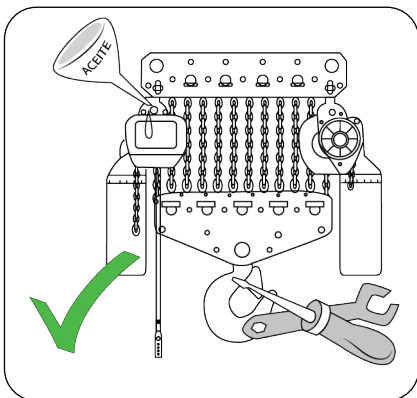

7. Regularly inspect and maintain your hoist.

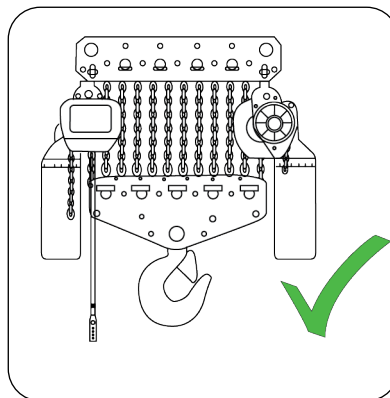

8. Always check correct hoist installation before use.

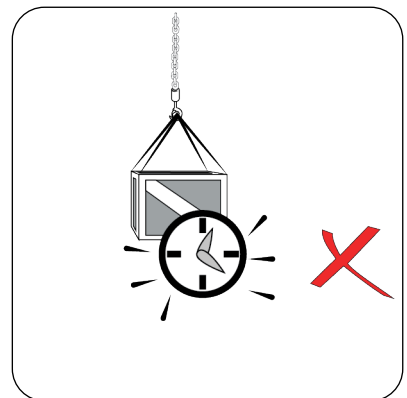

9. Do not leave the load suspended for long periods of time. It may cause deformation of the component or cause an accident.

GENERAL ENVIROMENTAL PRECAUTIONS

Do not exceed the operating temperatures for which the hoist is designed. This is stated in this manual and may vary depending on the model.

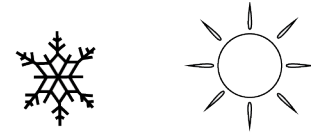

Avoid contact with gases or explosive materials.

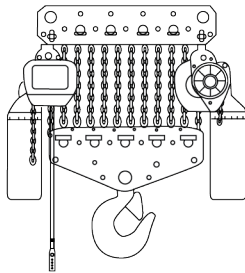

This equipment may be damaged when exposed to water, sand, corrosive environment and/or other potentially harmful substances.

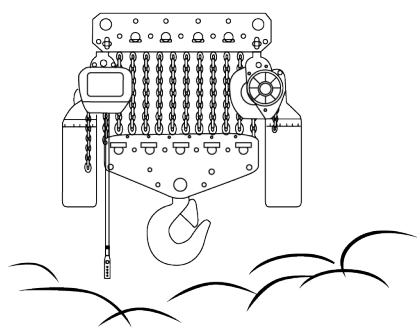
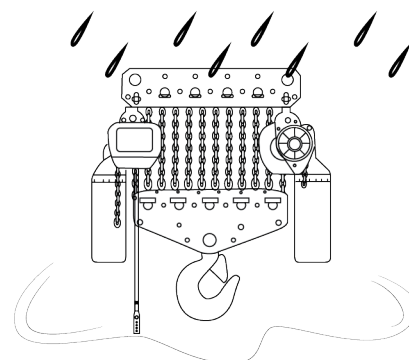

WARNINGS



Hanging Pendant Control

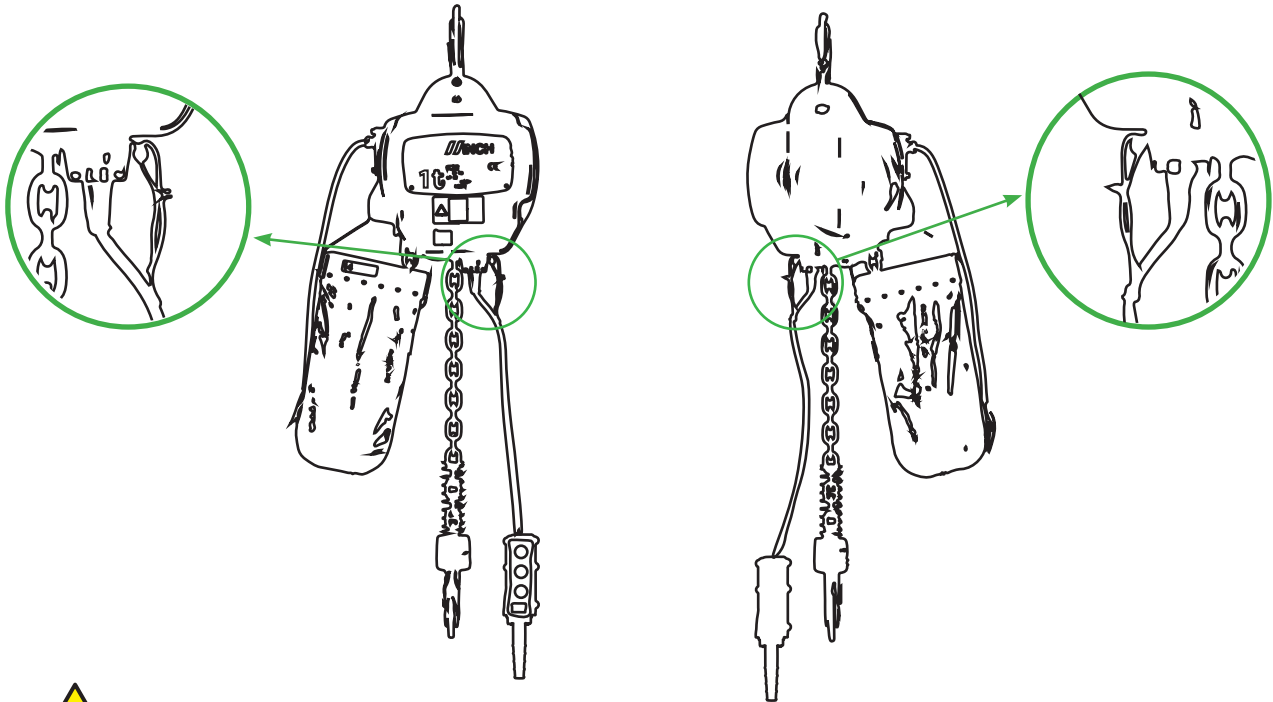

Make sure to connect both cables.

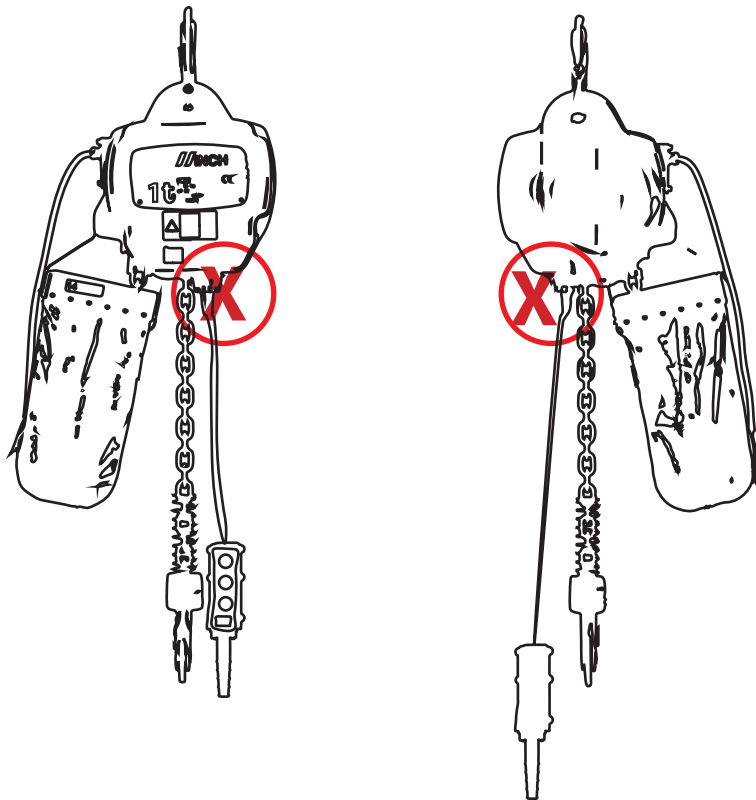

DANGER:

Do not install the pendant control cable without the strain relief cable (steel cord).

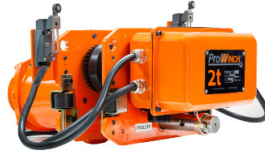

1. Electric Trolley

The range of flange width is adjustable. The motor includes disc-type brakes. Side guides promote smooth trolley motion and minimize wheel and beam wear.

1



2. Upper and lower limit switch

The limit switch will cut off the motor circuit and prevent the damage to hoist structure and load chain when over-lifting or over-lowering happens.



3. Chain Wheel

Increasing the number of load sheave pockets helps relieve vibrations produced by revolving polygonal sheave on the hoist's body and load chain.



4. Chain Bag

Canvas chain containers are standard fittings. Operation fabricated steel containers are available for long lift applications.

4



5. Control System

The length of the control is 4 feet less than the lifting height, which allows it to be easily operated from ground-level. An optional wireless remote control is available for extra convenience.



6. Reverse Phase Protector

In the case of a wiring error in the power supply, the special electrical installation for controlling the circuit does not work

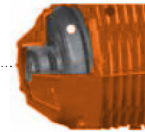

7. Safe Brake System

Electric brake is designed for easy access and simple adjustment. It allows instant brake as soon as the electric power is cut off. Thus the braking safety while loading is guaranteed.



8. Heavy Duty Stator

Made from light aluminum alloy shell. The cooling fin is specially designed to ensure quick heat dissipation with the rate up to 40% while operating at continuous service.



9. Load Chain

Canvas chain container is a standard fitting. Fabricated steel containers are available for long lift applications.



10. Hooks

Load hook is forged carbon steel hook with a heavy-duty hook latch. Thrust bearing in hook allows 360

ADVANTAGES

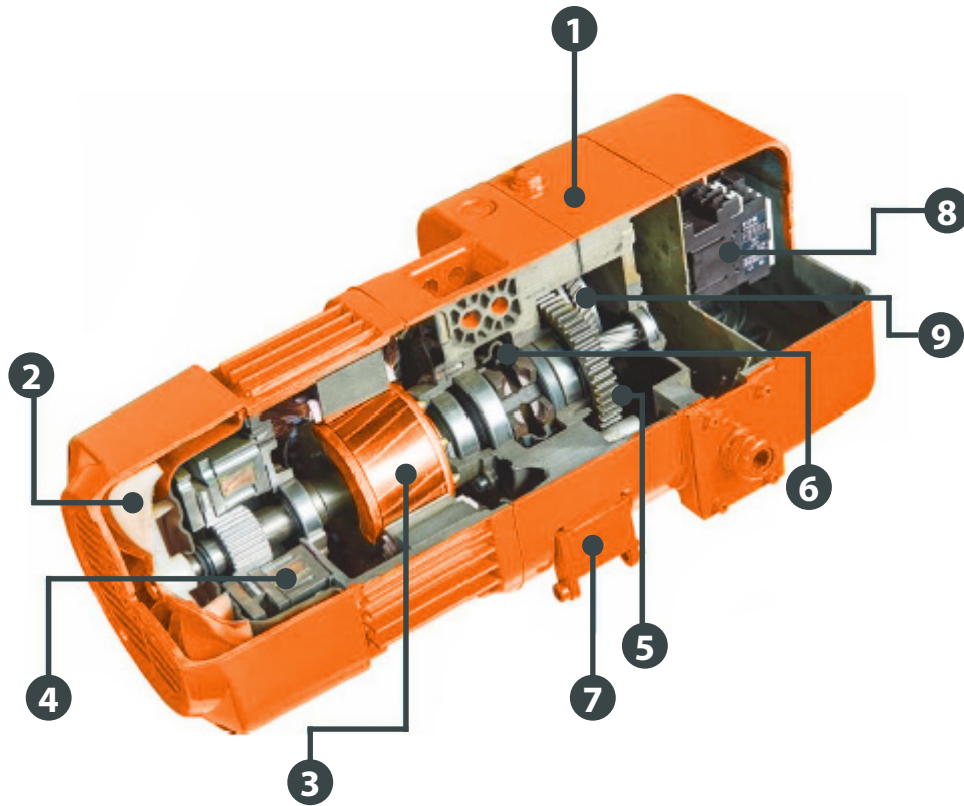

1. All aluminum die-cast body, making hoist light weight.
2. Cooling fan for motor creates longer product life.
3. Protection from motor overheating
4. Brake system: Electronic magnetic brake
5. Safety clutch for protection from overload
6. Unique guide structure
7. Limit switch for upper and lower: 20° lifting angle allowance
8. Self-lock contactor
9. Safety clutch

MAIN SPECIFICATIONS

Specification Chart (For all models of Prowinch® Electric chain hoists).

ITEM #	SPECS		
Operating temperature range (°C)	-20 to + 40		
Operating humidity range (%)	85 Or Below		
Protection class	Hoist	IP55	
	Button Switch	IP55	
Power		3 phases, 200 - 600V, 50/60Hz	
Noise level (dB)	Single speed hoist	81	
Chain specs	Double speed hoist	81	
Chain specs	Working load limit	Diameter (mm)	Chain pitch (mm)
	0,3T, 0,5T	6,3	10
	1T, 2T, 3T	7,1	21
	1,5T, 2T	10	30
	2,5T, 3T, 5T, 7,5T, 10T, 15T, 25T	11,2	34

Observations

Do not use Prowinch® Electric Chain Hoists when temperature and humidity exceed range of Specification Chart.

Our hoists are designed to lift up and down under common atmospheric and working conditions.

Load Level And Service Life

Guarantee of service life and safety for Prowinch® Electric Chain Hoists depends on proper installation, maintenance, and operation.

Our electric chain hoists are designed to meet 1Bm, 1Am and 2M Load Level in FEM standards FEM 9.51, depending on the model.

The working class of your chain hoist is rated on ID plate of equipment.

LOAD LEVEL	DEFINITION	CUBIC VALUE	AVERAGE DAILY OPERATION HOURS					
1 (light)	Mechanism and parts are frequently under light load, and there is under light load, and there is no max. load unless exceptional conditions.	$K \leq 0.50$	≤ 2	2 ~ 4	4 ~ 8	8 ~ 16	≤ 16	> 16
2 (medium)	Mechanism and parts are frequently under light load, but also under max. load with low frequency	$0.50 < K \leq 0.63$	≤ 1	1 ~ 2	2 ~ 4	4 ~ 8	8 ~ 16	≤ 16
3 (heavy)	Mechanism and parts are frequently under medium and heavy load.	$0.63 < K \leq 0.80$	≤ 0.5	0.5 ~ 1	1 ~ 2	2 ~ 4	4 ~ 8	8 ~ 16
4 (overweight)	Mechanism and parts are frequently under max. or almost reach max. load.	$0.80 < K \leq 1$	≤ 0.25	0.25 ~ 0.5	0.5 ~ 1	1 ~ 2	2 ~ 4	4 ~ 8
			1 BM	1:00 AM	2M	3M	4M	5M

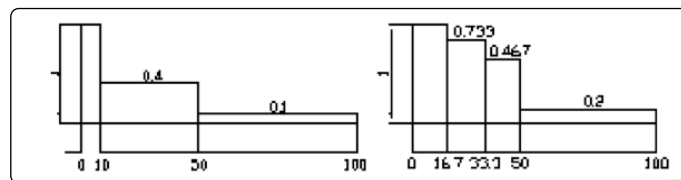

% Operation hours
Load level 1

% Operation hours
Load level 2

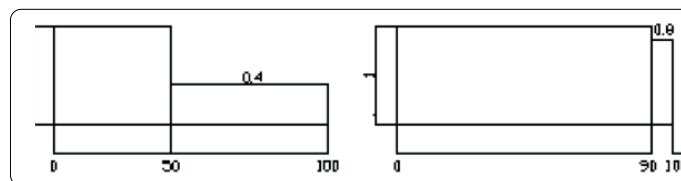

% Operation hours
Load level 3

% Operation hours
Load level 4

Selection of engines for lifting equipment

Group		Intermittent Service			Short-Term Service
F.E.M.	ISO	Cycles/h	Starts/h	(ED%)	Operation period min
1 DM	M1	15	90	15	7.5
1CM	M2	20	120	20	7.5
1 BM	M3	25	250	25	15
1:00 AM	M4	30	180	30	15
2 MW	M5	40	240	40	30
3M	M6	50	300	50	30
4M	M7	60	360	60	60
5M	M8	60	360	60	>60

Capacity (ton)	A	B	D	R	T	Speed (50HZ) m/min	Motor (Kw)	Min. Radius of turn	Beam Range
0.5	248	196	25	146	159	12.2	0.12	0.8	100

Capacity (ton)	A	B	D	R	T	Speed (50HZ) m/min	Motor (Kw)	Min. Radius of turn	Beam Range
1	315	212	31	142	231	nov-21	0.4	0.8	52 - 145
2	325	220	36	142	231	nov-21	0.4	0.9	82 - 185
3	340	250	43	142	231	nov-21	0.75	1.0	100 - 185
5	400	291	54	142	231	nov-21	0.75	1.5	100 - 220
7.5	400	291	54	142	231	nov-21	0.75	1.8	100 - 225
10	500	370	70	142	231	nov-21	0.75	2.0	150 - 255

Capacity (ton)	A	B	D	E	R	T	Speed (50HZ) m/min	Motor (Kw)	Min. Radius of turn	Beam Range
1	325	230	31	32	142	231	nov-21	0.4	0.8	52 - 145
2	375	245	31	44	142	231	nov-21	0.4	0.9	82 - 185
3	400	250	36	44	142	231	nov-21	0.75	1.0	100 - 185
5	420	290	43	44	142	231	nov-21	0.75	1.5	100 - 220

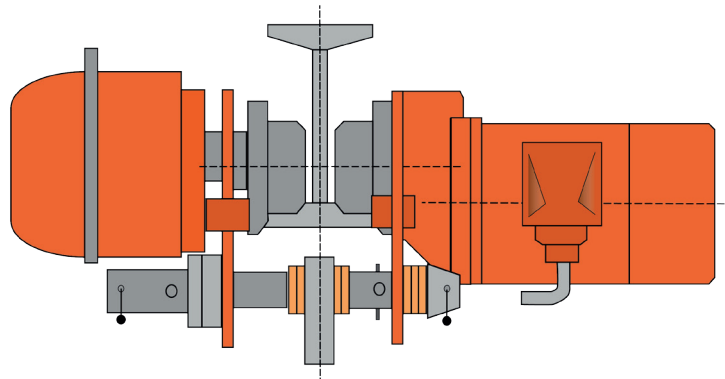

Oil & Lubricant Recommendations Capacity

Load Chain

Do not allow the chain to run without proper lubrication.

Lubricant significantly increases the life of the load chain. Weekly lubrication and cleaning must take place. But under hot, dirty, and extreme conditions, cleaning the chain at least once a day may be necessary, as well as lubricating it several times between cleaning. Apply sufficient lubricant to obtain natural runoff and full coverage, especially in interlink areas. Apply Lubriplate® Bar and Chain Oil 10-R or equal lubricant. Machine or gear oil (grade ISO VG 46 or 68 oil or equivalent) may be used as an alternative lubricant but must be applied more frequently.

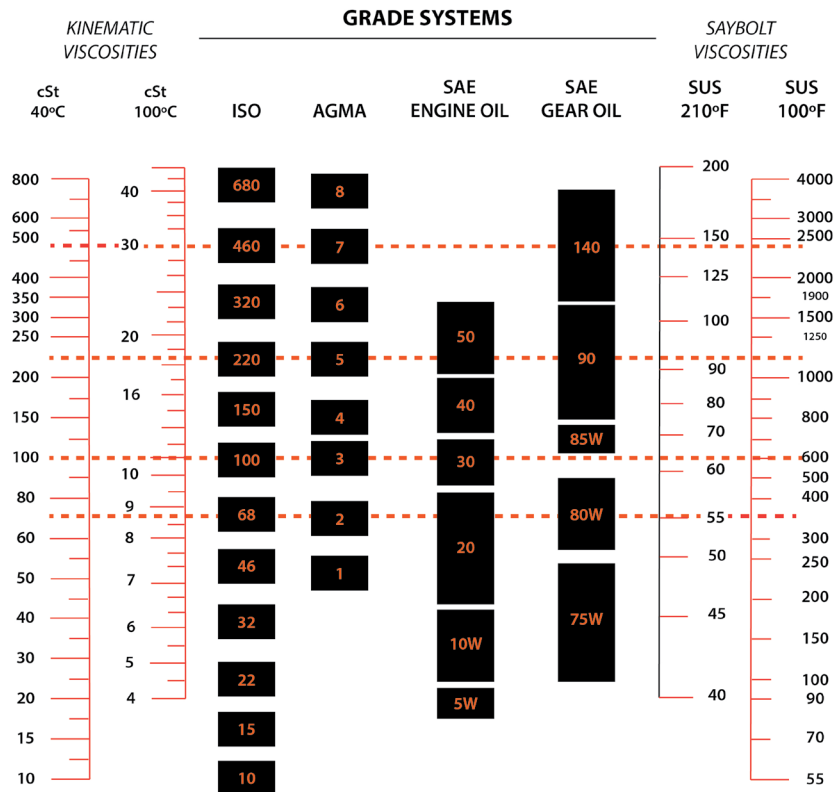

For dusty environments, it is acceptable to substitute a dry lubricant.

- Apply lubricant to areas of load chain (shaded areas in figure below) that contact load sheave.
- Hooks and Suspension Components
- Hooks and bearings should be cleaned and lubricated at least once per year for normal usage.
- Clean and lubricate more frequently
- for heavier usage or severe conditions.
- Suspension pins should be lubricated at least twice per year for normal usage; more frequently for heavier usage or severe conditions.

INSPECTIONS & MAINTENANCE

Periodic Inspection

Daily Inspection Of Electric Chain Hoists

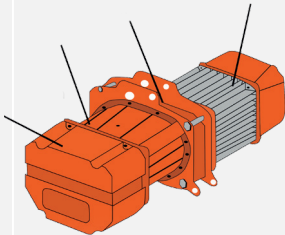
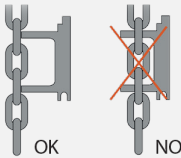
ITEMS	INSPECTION METHODS	STANDARDS	Resolutions to Deviations
Marks such as name-plates, labels etc.	Visual check	No peeling and clear marks 	Proceed with cleaning, repairing and replacing. Record serial number for replacing
Deformation or damage of body parts		No remarkable deformation, damaged or defect and chap	Replace parts which are deformed, damaged, and defective
Bolts, nuts, and cutters loose or falling off	Visual and tool check	<ul style="list-style-type: none"> • Correct installation • A loose bolt will cause equipment failure • Ensure proper installation to avoid death or serious injury 	Precise installation
Extent of pitch	Check by chain measurement tool		

<p>Attention of chain diameters</p>	<p>Check by chain measurement tool</p>		
<p>Deformation, damage, wind</p>	<p>Confirm chain is not stuck to welding spatters by visual inspection</p>	<ul style="list-style-type: none"> • No deep cut • No deformation • No welding spatters <ul style="list-style-type: none"> • No wind • No chap 	<p>Replace load chains</p>
<p>No extensive rust or corrosion</p>	<p>Visual check</p>	<p>No remarkable rust and corrosion</p>	<p>Replace load chains</p>
<p>Distortion</p>	<p>Visual check</p>	<p>No distortion due to bottom block rollover of double chain models</p> 	<p>Correct distortion</p>
<p>Oil supply</p>	<p>Visual check</p>	<p>Adequate supply of oil</p> 	<p>Oiling</p>

Limit switch	Check by pushing button	Operate until upper and lower limit cause automatic motor shutdown	Replace limit switch, disassemble and clean limit lever																																																															
Movement confirmation	Check by pushing button	<ul style="list-style-type: none"> • Load chain can roll up easily • Motor shutdown immediately when operation stops • All movements shutdown when E-stop button pushed • Other buttons cannot cause movement when pushing the E-stop button • All movements return to normal operation when E-STOP button relieved 																																																																
Brake	Check by pushing button	Brake quickly activates and operation of bottom hook immediately stops (amount of movement of the load chain is within 2 to 3 rings)																																																																
Chain spring	Visual inspection and measure dimensions	<table border="1"> <thead> <tr> <th rowspan="2">CHAIN</th> <th colspan="2">Length Of Spring</th> </tr> <tr> <th colspan="2">Standard</th> </tr> </thead> <tbody> <tr> <td>Ø6.3</td> <td>145</td> <td>140</td> </tr> <tr> <td>Ø7.1</td> <td>145</td> <td>140</td> </tr> <tr> <td>Ø10.0</td> <td>135</td> <td>129</td> </tr> <tr> <td>Ø11.2</td> <td>160</td> <td>152</td> </tr> </tbody> </table>	CHAIN	Length Of Spring		Standard		Ø6.3	145	140	Ø7.1	145	140	Ø10.0	135	129	Ø11.2	160	152	Replace chain spring 																																														
CHAIN	Length Of Spring																																																																	
	Standard																																																																	
Ø6.3	145	140																																																																
Ø7.1	145	140																																																																
Ø10.0	135	129																																																																
Ø11.2	160	152																																																																
Attrition and opening of the hook	Check by visual and vernier caliper	No remarkable opening or attrition <table border="1"> <thead> <tr> <th>LOAD</th> <th>A</th> <th>B</th> <th>C</th> <th>D</th> <th>E</th> <th>G</th> </tr> </thead> <tbody> <tr> <td>0.3-0.5</td> <td>27</td> <td>18</td> <td>25</td> <td>17</td> <td>35</td> <td>28</td> </tr> <tr> <td>1</td> <td>34</td> <td>24</td> <td>30</td> <td>24</td> <td>42</td> <td>32</td> </tr> <tr> <td>2</td> <td>46</td> <td>29</td> <td>39</td> <td>30</td> <td>49</td> <td>40</td> </tr> <tr> <td>3</td> <td>56</td> <td>35</td> <td>49</td> <td>34</td> <td>59</td> <td>48</td> </tr> <tr> <td>5</td> <td>67</td> <td>43</td> <td>67</td> <td>44</td> <td>60</td> <td>48</td> </tr> <tr> <td>7.5-10</td> <td>82</td> <td>55</td> <td>80</td> <td>48</td> <td>85</td> <td>80</td> </tr> <tr> <td>15</td> <td>110</td> <td>78</td> <td>120</td> <td>80</td> <td>120</td> <td>90</td> </tr> <tr> <td>20-25</td> <td>142</td> <td>95</td> <td>155</td> <td>98</td> <td>150</td> <td>115</td> </tr> </tbody> </table>	LOAD	A	B	C	D	E	G	0.3-0.5	27	18	25	17	35	28	1	34	24	30	24	42	32	2	46	29	39	30	49	40	3	56	35	49	34	59	48	5	67	43	67	44	60	48	7.5-10	82	55	80	48	85	80	15	110	78	120	80	120	90	20-25	142	95	155	98	150	115	
LOAD	A	B	C	D	E	G																																																												
0.3-0.5	27	18	25	17	35	28																																																												
1	34	24	30	24	42	32																																																												
2	46	29	39	30	49	40																																																												
3	56	35	49	34	59	48																																																												
5	67	43	67	44	60	48																																																												
7.5-10	82	55	80	48	85	80																																																												
15	110	78	120	80	120	90																																																												
20-25	142	95	155	98	150	115																																																												

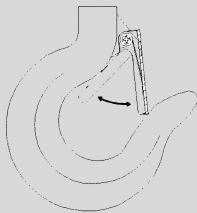
Deformation, damage and corrosion	Visual check	No extensive deformation, harmful damage or corrosion	Replace hook
Hook safety block	Visual inspection, fold and unfold actions	<p>-Can exactly fold inside the hook</p> <p>-No deformation</p> <p>Dangerous</p> <p>-Do not use hook if safety block is loosening</p> <p>Improper use will lead to death or serious injury</p>	<p>Replace hook safety block</p> 
Hook movements (rotate)	Visual inspection and manual rotation	<ul style="list-style-type: none"> • No remarkable space between bottom supporting and top • equal at right and left • easy to rotate 360° 	Replace hook

Installation Process:

- Electric chain hoists must be grounded properly.
- Lock-out and tag-out the main disconnect switch in de-energized position before performing any service on hoist.
- Customer must provide power supply cable, fuses, and main disconnect switch.
- Check supply voltage is same as nameplate voltage on hoist.
- Check voltage does not vary by more than ±10% from nominal value.
- Do not use conductors smaller than those listed in this User Manual to supply power to hoist.
- Never bypass limit switches, remove limit switch stops, or alter limit switch devices.

Unpacking

You should carefully inspect hoist upon delivery for any damage which may have occurred during shipment or handling. Check hoist frame for: dents or cracks, external cords for damaged or cut insulation, control station for cut or damaged enclosure, and load chain for nicks and gouges.

1 Chain Bag (Box)	1Pcs
2 Control Wire Rope	1m
3 Button Switch	2 Pcs

Check and document hoist characteristics:

- Model number
- Rated capacity (tonnage)
- Lifting length of load chain (meter)
- Power supply
- Push button pendant assembly (2 button, 4 button or 6 button)
- Specially ordered optional items
- Beam width for trolley installation

Chain Bag Assembly

Switch on power supply to hoist and have professional operate push button.

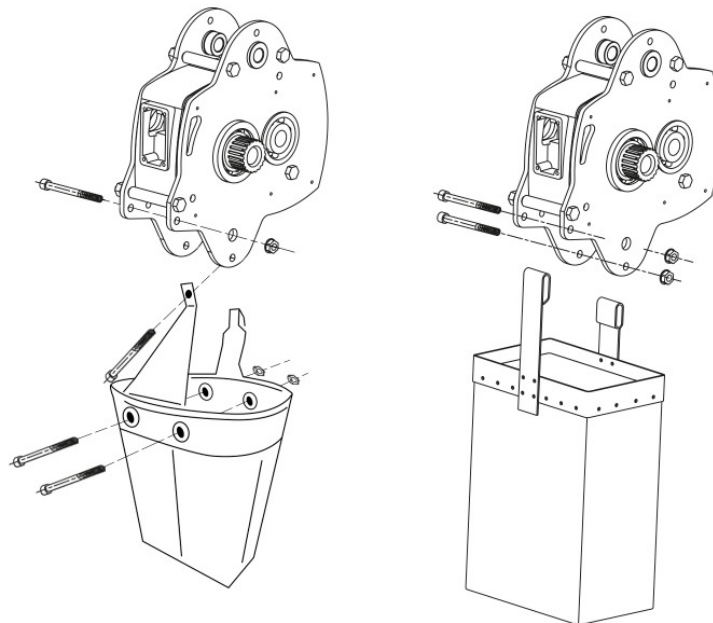

Trolley Installation (models with trolley)

1. Insert suspension pins into lateral plate G and lock it with suspension pin bolts and nuts.
2. Install suspension pin with adjusting disk.
3. Install suspension pin into hanger T. The nameplates of hoist and trolley should be in the same direction.
4. Install additional gaskets into suspension pin before inserting it into lateral plate S.
5. Install outside adjusting disk and spacer pin into suspension pin. Insert cotter pin into spacer pin.
6. Cotter pin should be seen at the left side from front of trolley switch box.

Adjust Trolley Width (models with trolley)

- Adjust width of trolley according to drawing (below) for appropriate clearance.
- Size A is the dimension of two side plates that stretch outside completely.
- Size A must be approximate B (the width of rail flange) + 4mm.
- Adjust size A by increasing or decreasing adjusting disk. Insert cotter pin into spacer pin and bend two branches of cotter pin until size A is correct.

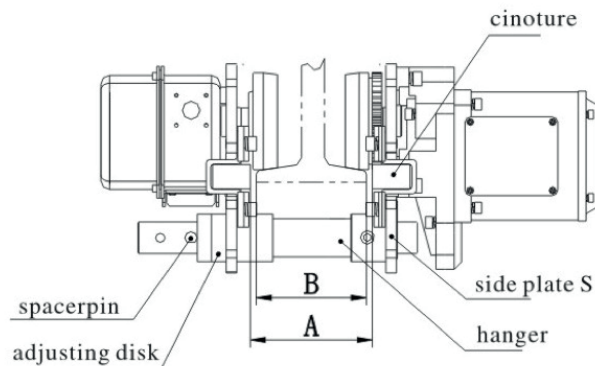

Nut must be tight, insert cotter pin and bend it completely.

Install Trolley Into Beam (models with trolley)

1. Install trolley at end side of beam and slip trolley which has already been connected with hoist to the appropriate place. This is the preferred method.
2. If first method is unavailable:
 - Unload brake stopper from hole A on suspension pin, and insert it into hole. Insert cotter pin again and bend it completely.
 - Pull side plate S and G outside, then lift trolley until orbit wheel and orbit surface are in same horizontal position. Put orbit wheel of side plate G onto surface of orbit.

- Hold side plate G and stop it from dropping from orbit. Firmly push side plate S and put its orbit wheel onto surface of beam.
- Unload brake stopper from hole B and insert into hole A. Do not forget to bend cotter pin.

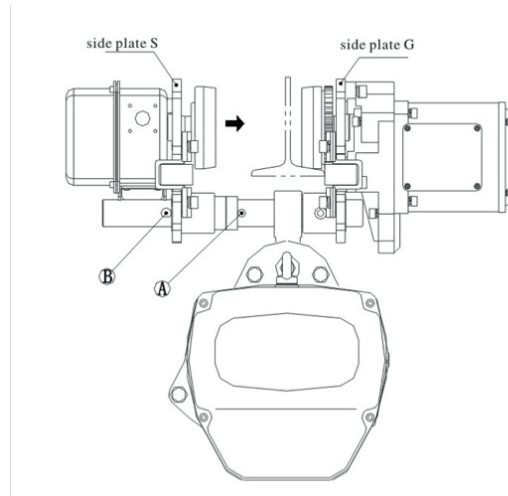

OPERATION

Qualified Operator

Safe and efficient operation of this hoist requires an operator who displays caution and careful judgment. The operator must be fully alert, focused, and aware of his/her surroundings. The operation of this equipment must be closely carried out under the good practices defined by international and national safety standards, such as ANSI, OSHAS and ASME.

Training must be provided to the operator to ensure proper operation of equipment in compliance with the instructions provided by this equipment manufacturer and the provisions of ASME B30.

This hoist must not be operated by someone who:

- Cannot read, understand or speak language of security labels, ID Plate and User Manual of equipment.
- Does not meet legal age requirements.
- Has visual or hearing impairments
- Experiences mental, heart, or other health issues that could interfere with safe operation of equipment.
- Has not been fully trained on the use of hoist.
- Has not received and read User Manual for exact equipment.
- Has not demonstrated qualifications through a practical operation of hoist

Handling Precautions





ALWAYS:

- Keep hoist in good condition and make sure chain is lubricated and free to operate.
- Make sure electrical connection is grounded.
- Make smooth movements; avoid sudden changes of directions.
- Check functions of hoist and trolley without any load before operation.
- De-energize equipment after using it to avoid unintentional operation.
- Keep everyone a distance of at least 1.5 times the length of chain. If load falls it can cause serious injuries and death.
- Make sure no one is beneath load.

NEVER:

- Use pulleys or other accessories that are not specifically approved for relevant hoist model.
- Hoist load with tip of hook.
- Hoist load which is not vertical to hook.
- Use hoist to pull or drag load.
- Exceed maximum capacity of hoist.

Recommended Operation

1. Press  button lowering unloaded hook down until limit spring touches limit switch. Be sure hoist stops automatically before totally compressing spring.
2. Press  button hoisting unloaded hook up until limit spring touches limit switch. Be sure hoist stops automatically before totally compressing spring.
3. Test correct function of emergency stop button. When pressing button ,  press emergency stop button. Ensure hoist stops immediately after pressing emergency stop switch. Hoist should not start again if any other movement button is activated.
4. Rotate emergency stop switch clockwise to original position. When it bounces back, hoist can be started again. If any of the above tests fail, unit must remain out of service, lockout/tagout power and request maintenance authorized personnel to check circuit layout for automatic locking emergency stop switch.
5. Check lubricating condition of load chain (load chain has been lubricated before delivery, but could be dried in transportation). Apply lubricant into chain bag to protect load chain.
6. 6. Check direction of chain eyes. All welding points should be same direction. Hoist cannot be operated properly unless all welding chain eyes are in same line.

- Position hoist in vertical position to load. Before moving trolley, ensure path of hook is free from all obstacles.
- Lower hook near master link to hoist load and make final adjustments to secure a 90° vertical lift operation without any lateral deviation. Improper angle may cause swinging of load.
- Attach hook to load link and make sure there are no people or obstacles in working area. Check that there are no loose items that could fall from load.
- Begin by hoisting load two inches and stop. Check brakes are fully operational, and load doesn't lower while stopped. Also check load is balanced and secured. Load may have changed shape or center of gravity when suspended.
- To reach a desired position, movements must be smooth and continuous. Repeatedly pressing control buttons will cause motor to overheat and damage equipment.
- Avoid sudden directions changes. These movements may damage equipment, prematurely wear down brakes and potentially cause accidents.



WARNING:

If hoist model has double dual/speed capabilities, always start with slower speed to avoid sudden accelerations. Decelerate before completing a stop.

7. Avoid any obstacle when hoisting or traveling load.
8. Start movement of trolley and check there is no swinging of load and no obstacles in path. Stop movement and make necessary adjustments if one of these conditions is present.
9. Once desired position is reached, slowly stop trolley. Position load completely vertical to desired spot where load will be lowered.
10. Gradually lower load until it is secured on resting surface. Avoid hitting surface at high speed. If necessary, stop movement before reaching surface and gradually lower to land load.



DANGER:

NEVER leave load suspended without attention of the hoist operator!

ELECTRICAL AND VOLTAGE SELECTION

Available voltages 3 phase 220V 60HZ , 380V 50HZ and 440V 60HZ
Before switching voltage!

	WARNING	
	<p>Read and understand operator's manual and all other safety instructions before using this equipment. This equipment must be operated by trained and experienced personnel only.</p>	

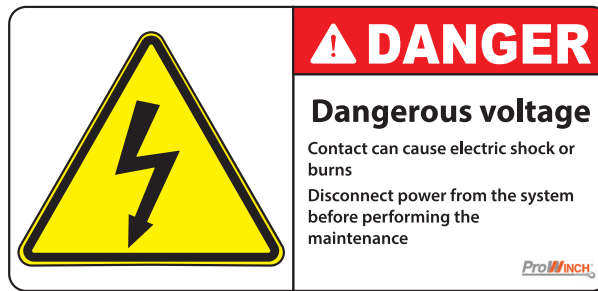

PWR_ and PWR_M5 series Triple Voltage Single Speed Electric Chain Hoist

1. Open electric box metal cover.
2. Locate 9 black lines coming from motor labeled with yellow tags as K1 - K2 - K3 - K4 - K5 - K6 - K7 - K8 and K9.
3. Depending on factory voltage preset, black wires/lines should be connected as follows:
 - 220V 60HZ all 9 lines are connected into contactor relays in set of 3 together as follows:
 - K1,K4,K7 @ U
 - K2,K5,K8 @ V
 - K3,K6,K9 @ W
 - 380V 50HZ only 3 lines are individually connected into contactor relays:
 - K1 @ U
 - K2 @ V
 - K3 @ W
 - Lines K4 - K5 - K6 - K7 - K8 and K9 are separately all connected.
 - 44V 60HZ only 6 lines are connected into the contactor relays in set of 2 together as follows:
 - K4,K7 @ U
 - K5,K8 @ V
 - K6,K9 @ W
 - Lines K1 - K2 and K3 are separately all connected.

Notes:

- Motor lines connected to contactors (U, V and W) are bridged between set of contactors.
- Unused lines shall be isolated from ground, properly connected among them and secured behind contactors.

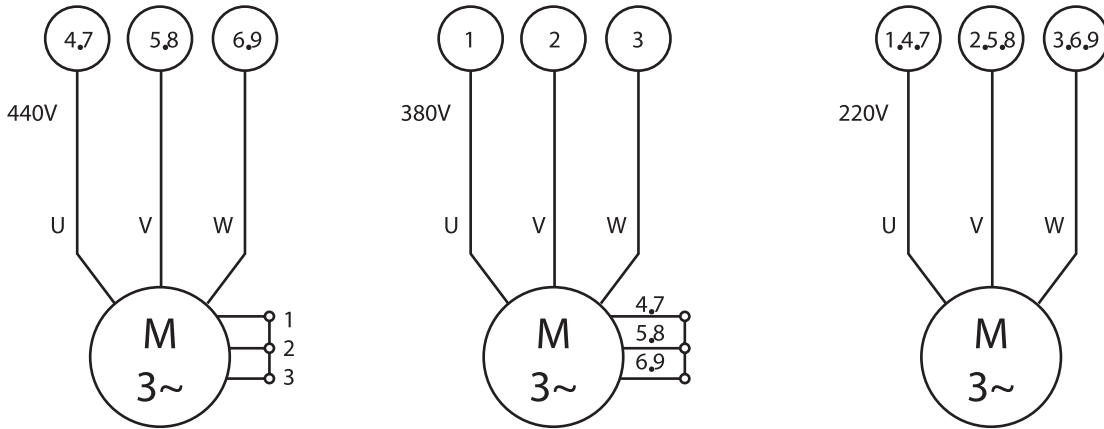

- Depending on voltage requirement, connect lines K1 - K2 - K3 - K4 - K5 - K6 - K7 - K8 and K9 as described above.
- Next to the contactors locate triple voltage power transformer, unplug input (1 wire/line) and plug it as voltage requirement. 220, 380 and 440V are easily displayed on transformer.
- Only for M5 units: Verify and replace Rectifier with corresponding voltage Voltage ranges 300~555V use Rectifier RH555 UHT 555V~0.75A Voltage ranges 198~270V use Rectifier RB270 UHT 270V~0.75A
- Check all connections are tight. Unused motor K lines shall be isolated from ground and properly connected among them as described in point 3.
- Properly place electric box cover.
- Remove old voltage tags and marks.
- Replace new voltage tags and marks with corresponding new voltage selected.
- Remove lockout/tagout and perform all corresponding inspection and testing as described on ASME B30.16-2.

PWRC and PWRC_M5 Series Triple Voltage Single Speed Electric Chain Hoist with Power Trolley

- Open electric box metal cover.

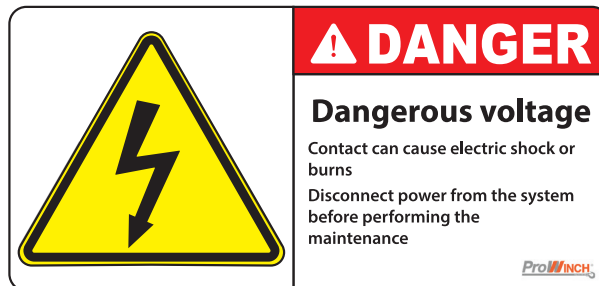

2. Locate 9 black lines from motor labeled with yellow tags as K1 - K2 - K3 - K4 - K5 - K6 - K7 - K8 and K9.
3. According to factory voltage black wires/lines connect as follows:
 - 220V 60HZ all 9 lines connect into contactors relays in groups as follows:
K1, K4, K7 @U K2, K5, K8 @V K3, K6, K9 @W
 - 380V 50HZ only 3 lines individually connect into contactors relays:
K1 @U
K2 @V
K3 @W
 - Lines K4 - K5 - K6 - K7 - K8 and K9 are separately connected.
 - 44V 60HZ only 6 lines connect into contactors relays in sets as follows:
K4, K7 @U
K5, K8 @V
K6, K9 @W
 - Lines K1 - K2 and K3 are separately connected.
- Notes:
 - Motor lines connected to contactors (U, V and W) are bridged between set of contactors.
 - Unused lines must be isolated from ground, properly connected, and secured behind contactors.
4. According to voltage requirement connect lines K1 - K2 - K3 - K4 - K5 - K6 - K7 - K8 and K9 as described above.
5. Locate black triple voltage power transformer next to contactors. Unplug input (1 wire/line) and plug according to voltage requirement. 220, 380 and 440V are displayed on transformer.
6. Only for M5 units: Verify and replace rectifier with corresponding voltage. For voltages ranging 300~555V use rectifier model RH555 UHT 555V~0.75A For voltages ranging 198~270V use rectifier RB270 UHT 270V~0.75A.
7. Ensure connections tightened, unused motor K lines must be isolated from ground and properly connected as described in point 3.
8. Open electric motor junction box on power trolley motor.
9. Locate 9 black lines coming from motor labeled with yellow tags as K1 - K2 - K3 - K4 - K5 - K6 - K7 - K8 and K9.
10. Preset black voltage wires/lines connect as follows:
 - 220V 60HZ all 9 lines connect into double row terminal block in groups as follows:
K1, K4, K7 @U K2, K5, K8 @V K3, K6, K9 @W
 - 380V 50HZ only 3 lines individually connect into double row terminal block: K1 @U K2 @V K3 @W
 - Lines K4 - K5 - K6 - K7 - K8 and K9 are separately connected.
 - 44V 60HZ only 6 lines connect into double row terminal block in sets as follows:
K4, K7 @U K5, K8 @V K6, K9 @W Lines K1 - K2 and K3 are separately connected.

Notes:

- Unused lines must be isolated from ground, properly connected and secured behind double row terminal block.

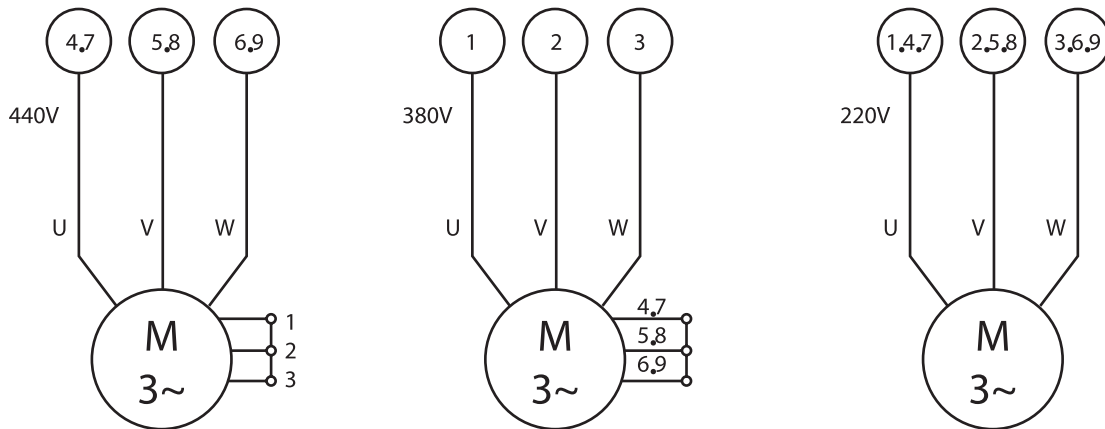

11. According to voltage requirement connect lines K1 - K2 - K3 - K4 - K5 - K6 - K7 - K8 and K9 in double row terminal block as described above.
12. Ensure connections tightened, unused motor K lines must be isolated from ground and properly connected as described in point 8
13. Properly set motor junction box cover.
14. Remove previous voltage tags and marks on hoist and trolley.
15. Replace voltage tags and marks with corresponding new voltage selected on hoist and trolley.
16. Remove lockout/tagout and perform all corresponding inspection and testing as described in ASME B30.16-2 and ASME B30.17-2

PWR_i and PWR_{M5i} Series Triple Voltage Double Speed Electric Chain Hoist

1. Open electric box metal cover.

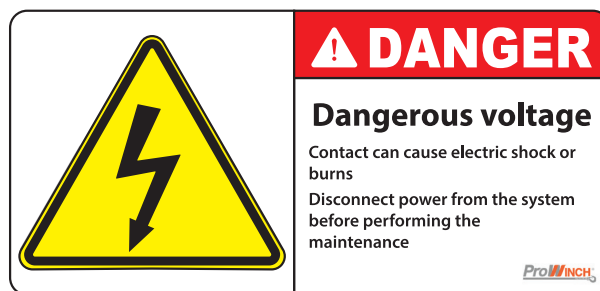

2. Locate 12 black lines coming from motor labeled with yellow tags as: High Speed: 6 thicker lines K1 - K2 - K3 - K4 - K5 and K6. Low Speed: 6 thinner lines K1 - K2 - K3 - K4 - K5 and K6.
3. Preset black voltage wires/lines connect as follows and repeat for thicker (High Speed) and thinner (Low Speed) lines:

- 220V 60HZ both sets of 6 lines connect into contactors relays in sets as follows:

K1, K2 @U K3, K4 @V K5, K6 @W

- 380V 50HZ and 44V 60HZ both sets of 3 lines individually connect into contactors relays:

K1 @U K3 @V K5 @W Lines K2 - K4 and K6 are separately connected.

Notes:

- Motor lines connected to contactors (U, V and W) are bridged between set of contactors.
- Unused lines must be isolated from ground, properly connected and secured behind contactors.

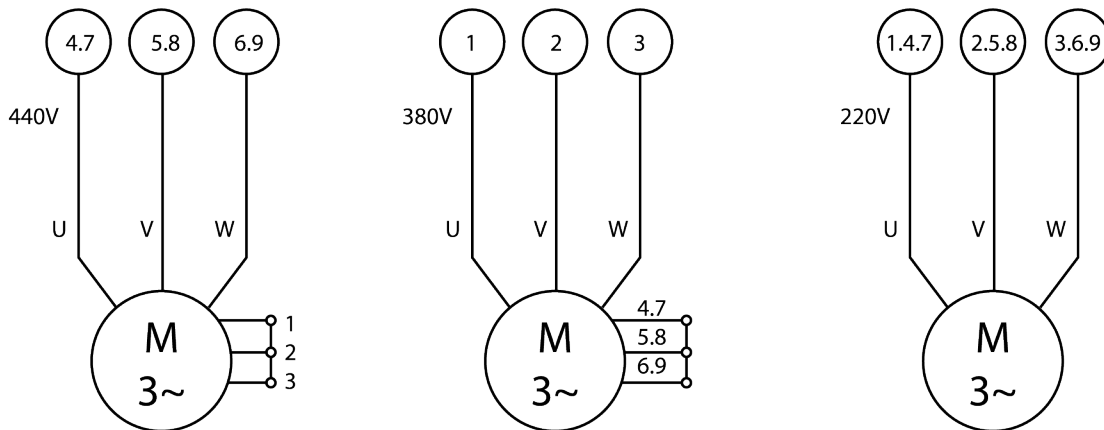

4. According to voltage requirement connect both sets of lines (thicker and thinner) K1 - K2 - K3 - K4 - K5 - and K6 as described above.

5. Locate black triple voltage power transformer next to contactors. Unplug input (1 wire/line) and plug according to voltage requirement. 220, 380 and 440V are displayed on transformer.

6. Only for M5 units: verify and replace rectifier with corresponding voltage. For voltages ranging 300~555V use rectifier model RH555 UHT 555V~0.75A For voltages ranging 198~270V use rectifier RB270 UHT 270V~0.75A

7. Ensure connections tightened, unused motor K lines must be isolated from ground and properly connected as described in point 3.

8. Properly set electric box cover.

9. Remove previous voltage tags and marks.

10. Replace voltage tags and marks with corresponding new voltage selected.

11. Remove lockout/tagout and perform all corresponding inspection and testing as described in ASME B30.16-2.

PWR_ and PWR_M5 series Triple Voltage Single Speed Electric Chain Hoist

1. Open electric box metal cover.

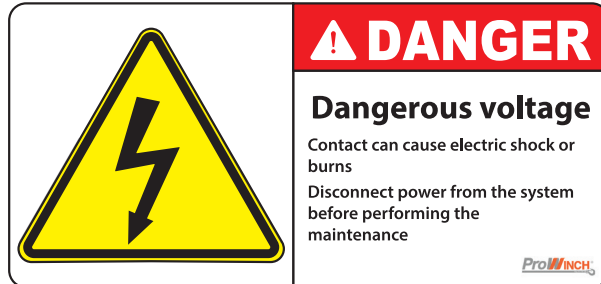

2. Locate 9 black lines coming from motor labeled with yellow tags as K1 - K2 - K3 - K4 - K5 - K6 - K7 - K8 and K9.
3. Depending on factory voltage preset, black wires/lines should be connected as follows:

- 220V 60HZ all 9 lines are connected into contactor relays in set of 3 together as follows:

K1,K4,K7 @ U

K2,K5,K8 @ V

K3,K6,K9 @ W

- 380V 50HZ only 3 lines are individually connected into contactor relays:

K1 @ U

K2 @ V

K3 @ W

Lines K4 - K5 - K6 - K7 - K8 and K9 are separately all connected.

- 44V 60HZ only 6 lines are connected into the contactor relays in set of 2 together as follows:

K4,K7 @ U

K5,K8 @ V

K6,K9 @ W

Lines K1 - K2 and K3 are separately all connected.

Notes:

- Motor lines connected to contactors (U, V and W) are bridged between set of contactors.
- Unused lines shall be isolated from ground, properly connected among them and secured behind contactors.

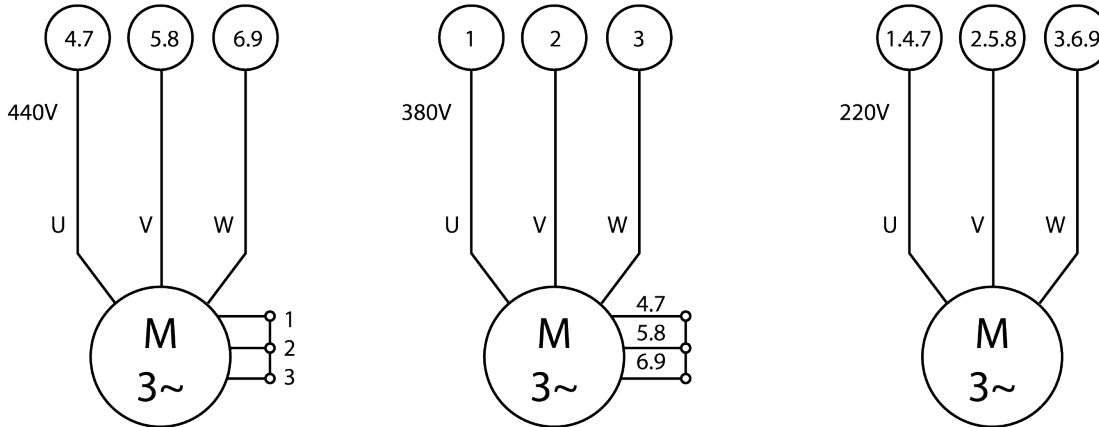

4. Depending on voltage requirement, connect lines K1 - K2 - K3 - K4 - K5 - K6 - K7 - K8 and K9 as described above.
5. Next to the contactors locate triple voltage power transformer, unplug input (1 wire/line) and plug it as voltage requirement. 220, 380 and 440V are easily displayed on transformer.
6. Only for M5 units: Verify and replace Rectifier with corresponding voltage.
 - Voltage ranges 300~555V use Rectifier RH555 UHT 555V~0.75A
 - Voltage ranges 198~270V use Rectifier RB270 UHT 270V~0.75A
7. Check all connections are tight. Unused motor K lines shall be isolated from ground and properly connected among them as described in point 3.
8. Properly place electric box cover.
9. Remove old voltage tags and marks.
10. Replace new voltage tags and marks with corresponding new voltage selected.
11. Remove lockout/tagout and perform all corresponding inspection and testing as described on ASME B30.16-2.

PWRC and PWRC_M5 Series Triple Voltage Single Speed Electric Chain Hoist with Power Trolley

1. Open electric box metal cover.
2. Locate 9 black lines from motor labeled with yellow tags as K1 - K2 - K3 - K4 - K5 - K6 - K7 - K8 and K9.
3. According to factory voltage black wires/lines connect as follows:
 - 220V 60HZ all 9 lines connect into contactors relays in groups as follows:
K1, K4, K7 @U K2, K5, K8 @V K3, K6, K9 @W
 - 380V 50HZ only 3 lines individually connect into contactors relays:
K1 @U

K2 @V

K3 @W

Lines K4 - K5 - K6 - K7 - K8 and K9 are separately connected.

- 44V 60HZ only 6 lines connect into contactors relays in sets as follows:

K4, K7 @U

K5, K8 @V

K6, K9 @W

Lines K1 - K2 and K3 are separately connected.

Notes:

- Motor lines connected to contactors (U, V and W) are bridged between set of contactors.
- Unused lines must be isolated from ground, properly connected, and secured behind contactors.

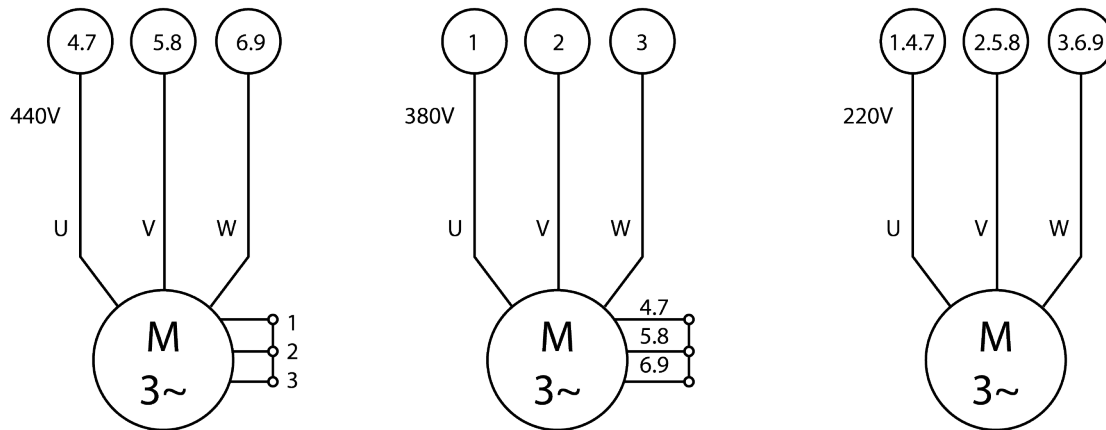

4. According to voltage requirement connect lines K1 - K2 - K3 - K4 - K5 - K6 - K7 - K8 and K9 as described above.
5. Locate black triple voltage power transformer next to contactors. Unplug input (1 wire/line) and plug according to voltage requirement. 220, 380 and 440V are displayed on transformer.
6. Only for M5 units: Verify and replace rectifier with corresponding voltage. For voltages ranging 300~555V use rectifier model RH555 UHT 555V~0.75A For voltages ranging 198~270V use rectifier RB270 UHT 270V~0.75A.
7. Ensure connections tightened, unused motor K lines must be isolated from ground and properly connected as described in point 3.
8. Open electric motor junction box on power trolley motor.
9. Locate 9 black lines coming from motor labeled with yellow tags as K1 - K2 - K3 - K4 - K5 - K6 - K7 - K8 and K9.
10. Preset black voltage wires/lines connect as follows:

- 220V 60HZ all 9 lines connect into double row terminal block in groups as follows:

K1, K4, K7 @U K2, K5, K8 @V K3, K6, K9 @W

- 380V 50HZ only 3 lines individually connect into double row terminal block: K1 @U K2 @V K3 @W

Lines K4 - K5 - K6 - K7 - K8 and K9 are separately connected.

- 44V 60HZ only 6 lines connect into double row terminal block in sets as follows:
K4, K7 @U K5, K8 @V K6, K9 @W Lines K1 - K2 and K3 are separately connected.

Notes:

- Unused lines must be isolated from ground, properly connected and secured behind double row terminal block.

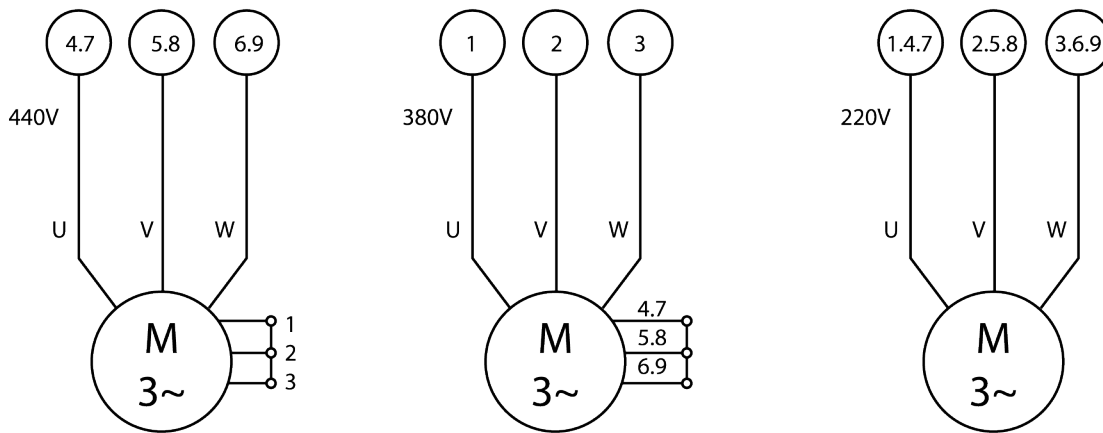

11. According to voltage requirement connect lines K1 - K2 - K3 - K4 - K5 - K6 - K7 - K8 and K9 in double row terminal block as described above.
12. Ensure connections tightened, unused motor K lines must be isolated from ground and properly connected as described in point 8
13. Properly set motor junction box cover.
14. Remove previous voltage tags and marks on hoist and trolley.
15. Replace voltage tags and marks with corresponding new voltage selected on hoist and trolley.
16. Remove lockout/tagout and perform all corresponding inspection and testing as described in ASME B30.16-2 and ASME B30.17-2

PWR_i and PWR_M5i Series Triple Voltage Double Speed Electric Chain Hoist

1. Open electric box metal cover.
2. Locate 12 black lines coming from motor labeled with yellow tags as: High Speed: 6 thicker lines K1 - K2 - K3 - K4 - K5 and K6. Low Speed: 6 thinner lines K1 - K2 - K3 - K4 - K5 and K6.
3. Preset black voltage wires/lines connect as follows and repeat for thicker (High Speed) and thinner (Low Speed) lines: - 220V 60HZ both sets of 6 lines connect into contactors relays in sets as follows:

K1, K2 @U K3, K4 @V K5, K6 @W

- 380V 50HZ and 44V 60HZ both sets of 3 lines individually connect into contactors relays:

K1 @U K3 @V K5 @W Lines K2 - K4 and K6 are separately connected.

Notes:

- Motor lines connected to contactors (U, V and W) are bridged between set of contactors.
- Unused lines must be isolated from ground, properly connected and secured behind contactors.

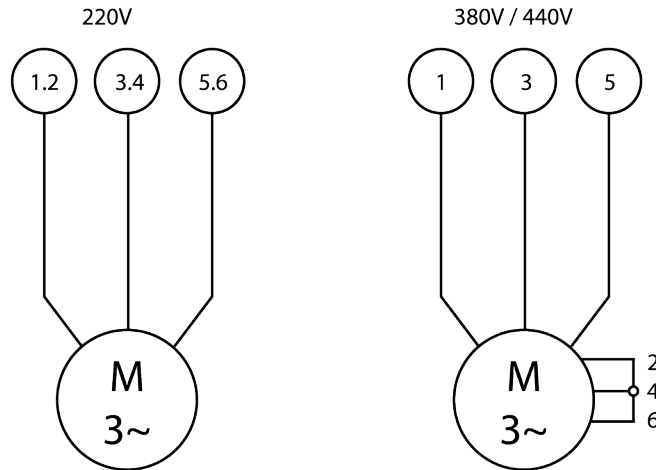

4. According to voltage requirement connect both sets of lines (thicker and thinner) K1 - K2 - K3 - K4 - K5 - and K6 as described above.
5. Locate black triple voltage power transformer next to contactors. Unplug input (1 wire/line) and plug according to voltage requirement. 220, 380 and 440V are displayed on transformer.
6. Only for M5 units: verify and replace rectifier with corresponding voltage. For voltages ranging 300~555V use rectifier model RH555 UHT 555V~0.75A For voltages ranging 198~270V use rectifier RB270 UHT 270V~0.75A
7. Ensure connections tightened, unused motor K lines must be isolated from ground and properly connected as described in point 3.
8. Properly set electric box cover.
9. Remove previous voltage tags and marks.
10. Replace voltage tags and marks with corresponding new voltage selected.
11. Remove lockout/tagout and perform all corresponding inspection and testing as described in ASME B30.16-2.

PWRC_i and PWRC_M5i series Triple Voltage Double Speed Electric Chain Hoist with Power Trolley

1. Open electric box metal cover.
2. Locate 12 black lines coming from motor labeled with yellow tags as: High Speed: 6 thicker lines K1 - K2 - K3 - K4 - K5 and K6. Low Speed: 6 thinner lines K1 - K2 - K3 - K4 - K5 and K6.
3. Preset black voltage wires/lines connect as follows and repeat for thicker (High Speed) and thinner (Low Speed) lines:

- 220V 60HZ both sets of 6 lines connect into contactors relays in sets as follows:

K1, K2 @U K3, K4 @V K5, K6 @W

- 380V 50HZ and 44V 60HZ both groups of 3 lines individually connect into contactors relays as follows:

K1 @U K3 @V K5 @W Lines K2 - K4 and K6 are separately connected.

Notes:

- Motor lines connected to contactors (U, V and W) are bridged between set of contactors.
- Unused lines must be isolated from ground, properly connected and secured behind contactors.

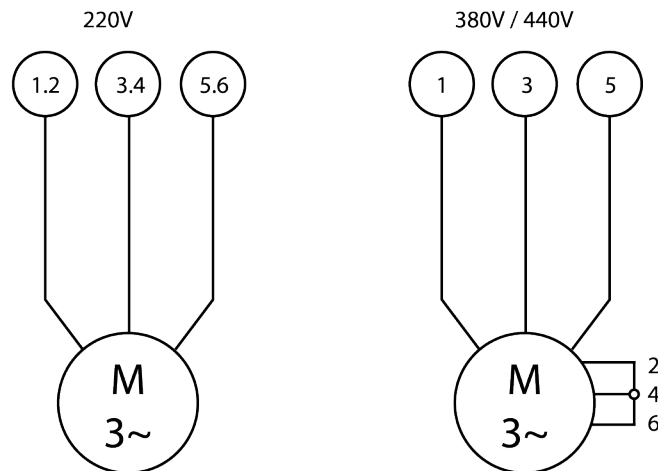

4. According to voltage requirement connect both sets of lines (thicker and thinner) K1 - K2 - K3 - K4 - K5 - and K6 as described above.

5. Locate black triple voltage power transformer next to contactors. Unplug input (1 wire/line) and plug according to voltage requirement. 220, 380 and 440V are displayed on transformer.

6. Ensure connections tightened, unused motor K lines must be isolated from ground and properly connected as described in point 3.

7. Open electric motor junction box on power trolley motor.

8. Locate 12 black lines coming from motor labeled with yellow tags as: High Speed: 6 thicker lines K1 - K2 - K3 - K4 - K5 and K6. Low speed: 6 thinner lines K1 - K2 - K3 - K4 - K5 and K6.

9. Preset black voltage wires/lines connect as follows and repeat for thicker (High Speed) and thinner (Low Speed) lines:

- 220V 60HZ both sets of 6 lines connect into double row terminal block in sets as follows:

K1, K2 @U K3, K4 @V K5, K6 @W

- 380V 50HZ and 44V 60HZ both sets of 3 lines individually connect into double row terminal block: K1 @U

K3 @V K5 @W Lines K2 - K4 and K6 are separately connected.

Notes:

- Motor lines connected to contactors (U, V and W) are bridged between set of contactors.
- Unused lines must be isolated from ground, properly connected and secured behind contactors.

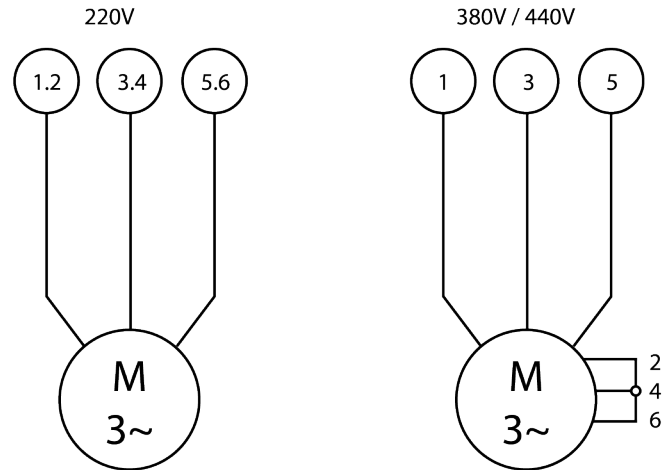

- 10.** According to voltage requirement connect both sets of lines (thicker and thinner) K1 - K2 - K3 - K4 - K5 - and K6 on double row terminal block as described above.
- 11.** Ensure connections tightened, unused motor K lines must be isolated from ground and properly connected as described in point 8.
- 12.** Properly set motor junction box cover.
- 13.** Remove previous voltage tags and marks on hoist and trolley.
- 14.** Replace voltage tags and marks with corresponding new voltage selected on hoist and trolley.
- 15.** Remove lockout/tagout and perform all corresponding inspection and testing as described in ASME B30.16-2 and ASME B30.17-2.

PROWINCH® WARRANTY

LIMITED WARRANTY COVERAGE

PROWINCH® products are warranted to the original purchaser for three (3) years after the date of purchase to be free from defects in material and workmanship when subjected to normal, proper, and intended use. Within the 3 years, and after examination, PROWINCH will only repair or replace free of charge any part on a product PROWINCH determines to be defective and not caused by other factors or circumstances beyond PROWINCH's control. That includes (but is not limited to) faulty installation, improper maintenance or repair, product modification or alteration, any neglect, misuse or excessive use, mishandling, product exposure to extreme or unsuitable conditions, normal wear and tear or failure to follow manufacturer's instructions. This warranty does not apply to damage PROWINCH determines to be from repairs made or attempted by anyone other than PROWINCH authorized personnel. Return of the product with a copy of proof of purchase to PROWINCH, freight prepaid, and insured, is required for this warranty to be effective. For this warranty to be effective after one year, the purchaser must provide proof of periodic and regular maintenance by an authorized service provider. PROWINCH does not cover freight or labor charges associated with the inspection and testing of products which PROWINCH finds not to be a valid warranty claim.

DISCLAIMER

In no event shall PROWINCH be liable for any labor, removal and installation expenses, loss of time, manufacturing costs, transportation, materials, loss of profits, incidental, special, consequential, or punitive damages, or for any costs, attorney fees, expenses, losses or delays, direct or indirect, alleged to be as a consequence of any damage to, failure of, or defect in any product including, but not limited to, any claims for loss of profits. PROWINCH disclaims any implied warranties, including, without limitation, any implied warranty of merchantability or fitness for a particular use or purpose. Acceptance of the exclusive repair and replacement remedies described herein is a condition of the contract for purchasing every PROWINCH product. You should not purchase the product if you do not agree to this condition.

CONVENTIONAL HOIST WIRING DIAGRAM (PWR - PWRC)

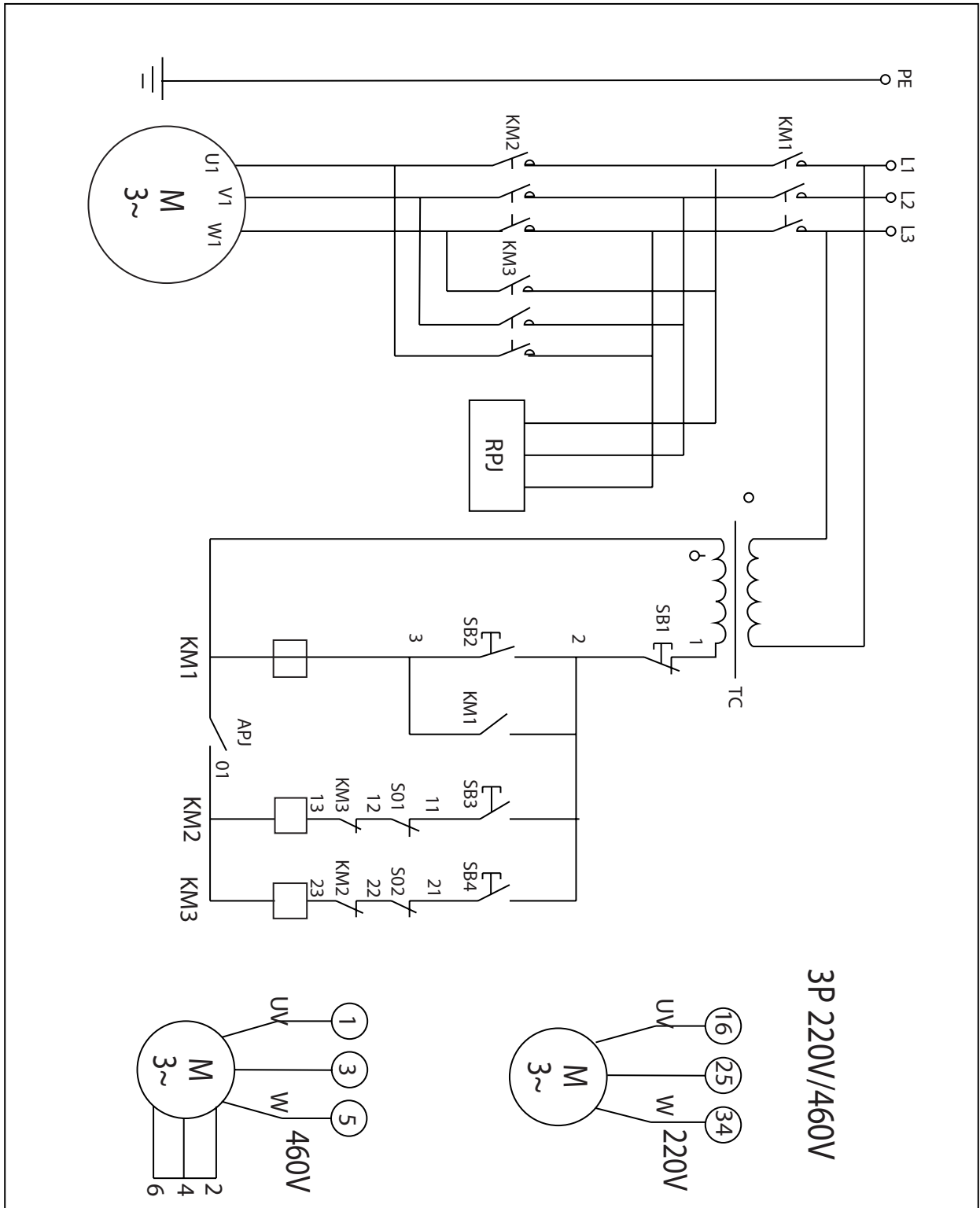

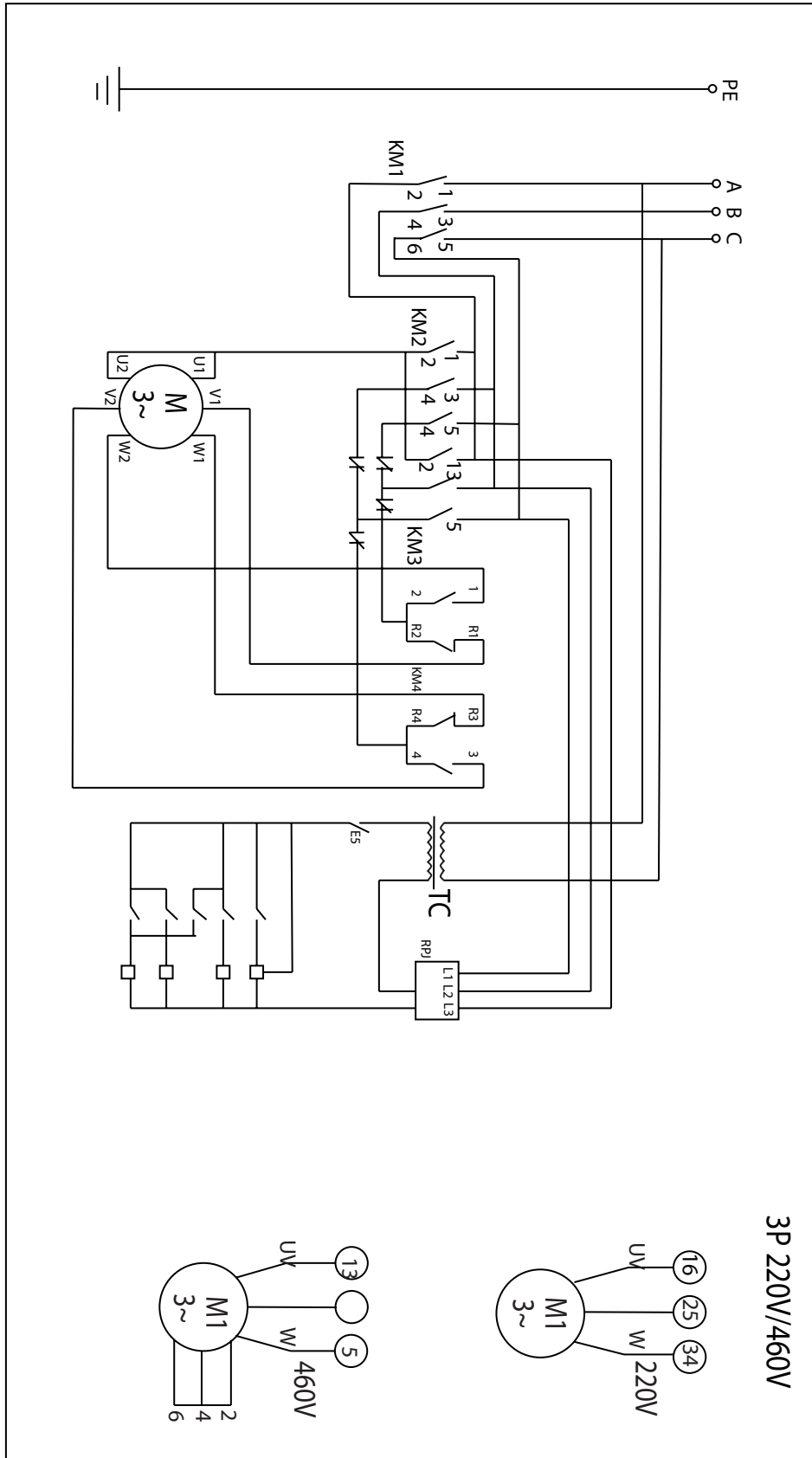

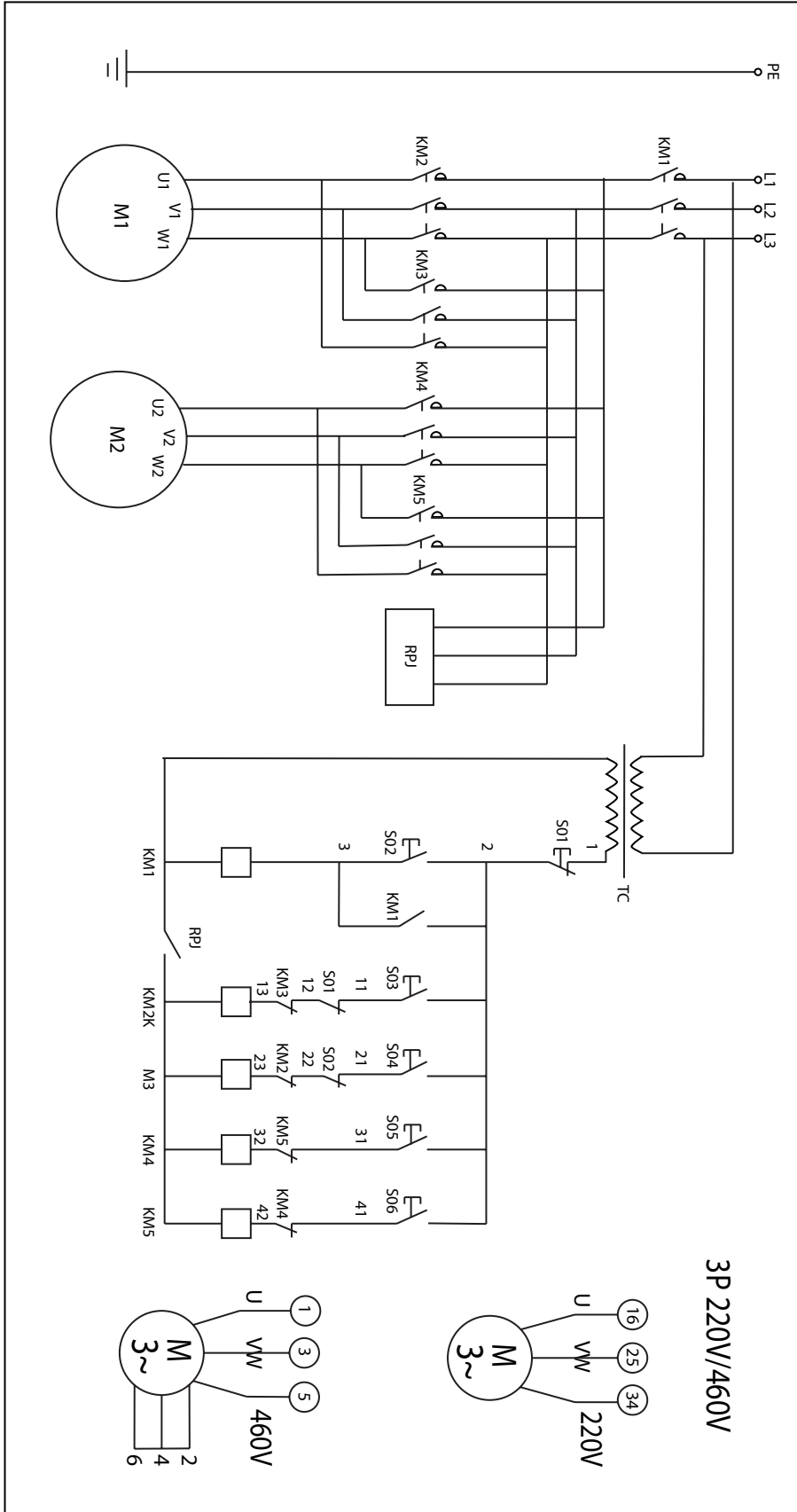

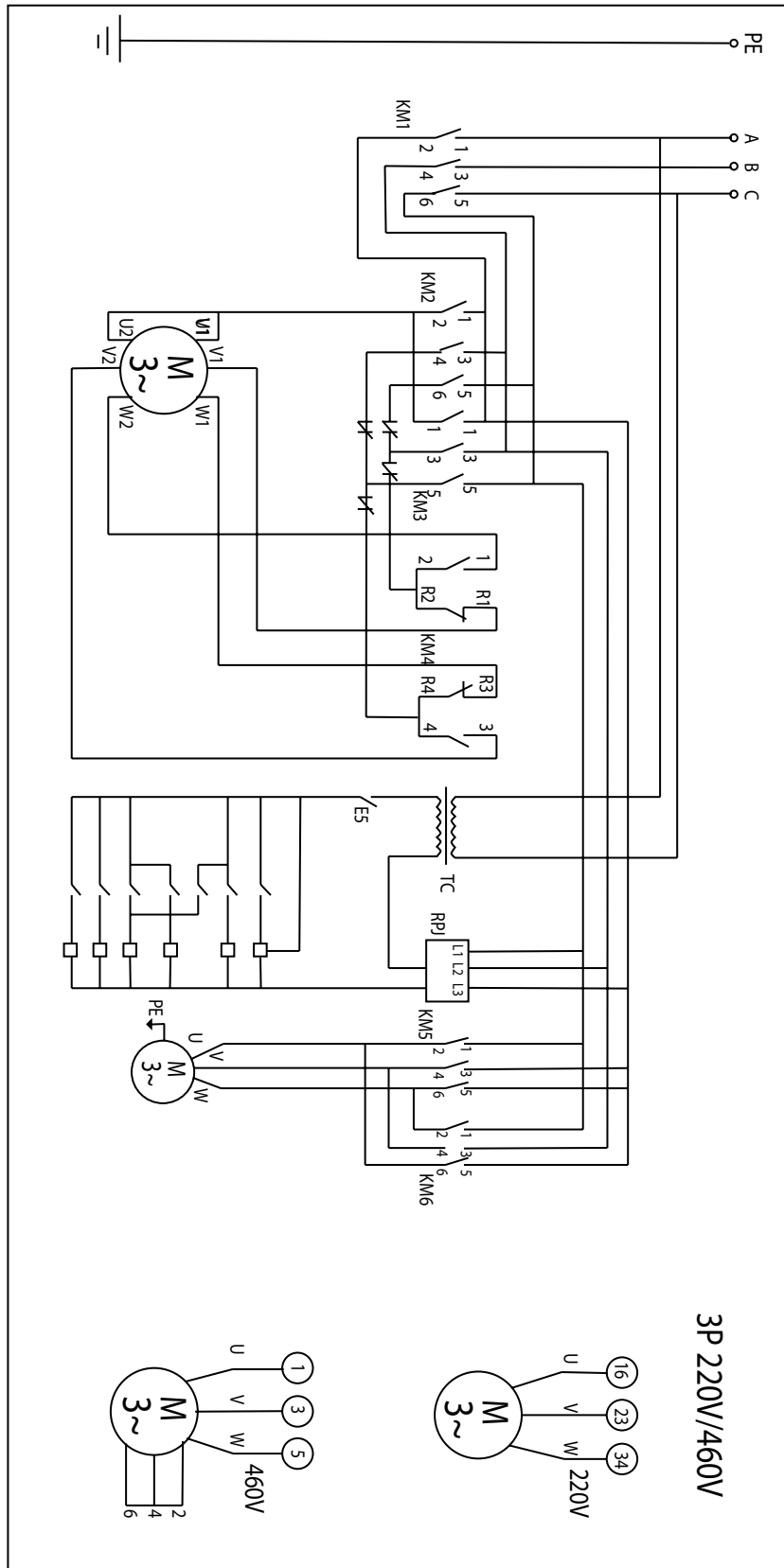

Faults, Cause, and Correction

Faults		Major Cause	Check Items	Remarks	
Does not operate in non-load state	Brake inaudible	Excessive voltage	Power		
		Operating circuit break-off, electric parts overheating	Power supply Internal wiring Contactor Transformer Up/Down limit switch Button switch		
	Contactor is inaudible	Power circuit break-off, overheating motor, brake	Motor Brake Internal wiring Contactor (junction		
	Brake audible	Drive overheating, broken bearing	Gear Bearing		
Operates in non-load state	Unable to lift (motor roar)	Default phase (single phase operation)	Power Feed power Motor Contactor(junction fusing)		
	Slow lifting	Low voltage	Feed power		
Unintended reaction from button	Inverse reaction from button	Anti-phase wiring	Feed power		
		Incorrect wiring	Internal wiring Button switch		
	No reaction after pressing button	Circuit wire break	Internal wiring Button switch		
		Electric installation parts	Contactor Up/Down limit switch Contactor Brake		
			Feed power Internal wiring Load chain Load pulley, bare pulley Gear Bearing		
	Noise of brake	Running (grating) Stop	Drag Wear of friction plate	Brake Brake	
	Abnormal noise of rail curve (grating)		Obstruction of orbit/wheel	Operation of trolley	

Faults, Cause, and Correction

Faults		Major Cause	Check Items	Remarks	
Does not move horizontally		Rail declining	Trolley movement		
	Electric trolley /manual trolley	Inclined pull (wheel is lifting)	Trolley movement		
	Electric trolley /manual trolley	Gear occlusion problem	Trolley movement		
	Electric trolley /manual trolley	Brake fastening	Trolley movement		
	Electric trolley	Electric faults	Trolley movement		
Irregular movement and noise	Electric trolley / manual trolley	Rail & wheel interference	Trolley movement		
		Side wheel lacks oil			
		Uneven wheel wear			
		Wheel deformation			
		Rail deformation, wear			
		Bearing wear			
		Brake wear			
Hook		Deformation	Hook		
Load chain		Wear, extension, deformation	Load chain		
Load chain		Equipment not properly grounded	Proper electric connection		
Does not operate in nonload state	Brake inaudible	Supply Power	Supply power voltage		
			Cables		
			Internal wiring		
		Operating circuit break-off, electric parts overheating	Transformer		
			Electrical relay		
			Limit switch		
	Brake audible	Braking interval too large or small.		Push Button Switch	
				Motor	
				Calibrate brake	
			Tripping as motor overheats	Thermal Protector	
Slow load operation	Voltage drop		Replace brake bearing		
			Bearing		
			Feed cable		
Low and high speed status not operating or working slow	Voltage drop		Supply power		
			Feed cable		
Movement does not correspond with switch button	Movement did not correspond with switch button	Motor wires connected	Motor		
		Connection error	Internal wiring		
	Switch button did not work	Operating circuit break-off	Push button switch		
		Electrical installation error	Internal wiring		

Faults, Cause, and Correction

Faults		Major Cause	Check Items	Remarks
Does not move horizontally	Electric trolley /manual	Rail declining	Trolley movement	
	Electric trolley /manual	Inclined pull (wheel is lifting)	Trolley movement	
	Electric trolley /manual trolley	Gear occlusion problem	Trolley movement	
	Electric trolley	Brake fastening	Trolley movement	
Irregular movement and noise	Electric trolley /manual trolley	Rail & wheel interference	Trolley movement	
		Side wheel lacks oil		
		Uneven wheel wear		
		Wheel deformation		
		Rail deformation, wear		
		Bearing wear		
		Brake wear		
Hook		Deformation	Hook	
Does not operate in nonload state	Brake inaudible	Supply power	Supply power voltage	
		Operating circuit break-off, electric parts overheating	Cables	
			Internal wiring	
			Transformer	
			Electrical relay	
	Push button switch			
	Brake audible	Braking interval too large or small.	Motor	
		Tripping as motor overheats	Calibrate brake	
			Thermal protector	
			Bearing burning out, driving component wear	Replace brake bearing
Bearing				
Slow load operation	Voltage drop	Feed cable		
Low and high speed status not operating or working slow	Low voltage	Supply power		
	Voltage drop	Feed cable		

Issues & Measures

Power supply

Condition	Reason	Action	Cause	Correction
No operation	Abnormal supply voltage	Power supply	Improper power supply	Check power supply regularly

Power Cable

Condition	Reason	Action	Cause	Correction
No operation	Wire break	Repair or change cable if broken	Strong force exerted	Firmly fix on cable support or other equipment
			2 or more	Use anti-vibration cable in movable part.
	Overheating	Check cables, exchange if overheating	Twisted, knotted	Straighten twists and knots
			Interference with other equipment	Use fixed cable and avoid outside interference
Starting slow or no operation	Off-capacity	Check cable diameter, replace cable if diameter is too small	Temperature rise due to off-capacity	Adopt the proper cable
			Binding cable used	Do not use binding cable
Starting slow or no operation	Off-capacity	Check cable diameter, replace cable if diameter is too small	Voltage drop	Adopt proper cable
Operation only in free load (single phase)	1 wire break or overheating	Refer to above break or overheating item		
Movement did not correspond with switch button (opposite)	Power line connection error	Replace wires	Wiring assembly error	Connect wire as per wiring diagram

Motor

Condition	Reason	Action	Cause	Correction
No operation	Coil burning (above 2 phase)	Measure phase resistance value; change motor if value is infinite.	Excessive current caused by high or low voltage	Operate under rated voltage
			Excessive current caused by overload	Operate under rated voltage
			Beyond short-term rating and intermittent cycle rating	Short-term rating, intermittent cycle rating, operate under rated voltage
				Avoid over-operation
				Excessive current caused by brake
Lead wire break (above 2phase)	Measure phase resistance value; change motor if value is infinite.	Lead wire broken in assembly	Change motor coil	
		Vibration, drop	Avoid excessive bumping in usage	
Operation only in free load (single phase state)	Coil burning (1 phase only)	Measure phase resistance value; change motor if value is infinite	Poor electric isolation	Ensure foreign matter does not enter motor
	Leading wire break (1 phase only)	Measure phase resistance value; change motor if value is infinite	Leading wire break in assembly	Change motor coil
			Vibration, drop	Avoid excessive bumping

Brake

Condition	Reason	Action	Cause	Correction	
No operation	Braking coil burning	Measure brake phase resistance value; change brake if value is infinite.	Excessive current caused by high or low voltage	Operate under rated voltage	
				Avoid over-operation	
			Excessive current caused by overload	Operate under rated voltage	
				Confirm short-term rating, intermittent cycle rating, operate under rated voltage	
				Excessive current caused by operation in single phase state	Stop immediately if unable to lift load in single phase
	Friction plate beyond brake magnetism scope	Measure brake clearance, replace if space is over usage limit			Avoid over-operation
	Broken brake wire	Ensure wire is connected, replace if disconnected	Lead wire damaged during assembly		Replace coil brake
	Improper connection of brake wire terminal	Replace insert terminal when loose	Assembly error		Proper connection in assembly
Rust	Replace brake if rust present		Exposure to water in storage	Ensure dry storage	
Friction plate wear	Measure brake clearance, replace if space is over use limit		Condensation	Monitor usage environments	
				Avoid over-operation	

Inside Wiring

Condition	Reason	Action	Cause	Correction	
No operation	Break	Check cable, repair if wire break	Vibration, drop	Avoid excessive bumping in usage	
			Leading wire damaged in assembly	Change motor coil	
			Connector not properly set	Press by appropriate tool	
	Wiring error	Refer to wiring diagram, ensure properly connected	Wiring error	Refer to wiring diagram, ensure properly connected	
	Connector screws loose (overheating)	Fastening		Improper fastening	Ensure effective fastening
				Vibration, drop	Avoid excessive bumping in usage
Connector, insert terminal improper combination	Proper combination		Bad combination during assembly	Ensure combination is effective	

Transformer

Condition	Reason	Action	Cause	Correction
No operation (Contractor)	Coil burning, break	Measure coil resistance value; Change transformer if value infinite	Excessive voltage	Operate under rated voltage
				Avoid over-operation
			Excessive current caused by contactor	Refer to contactor items
			Vibration, drop	Avoid excessive bumping in usage
	Wire break	Check leading wire, repair or change transformer if wire	Vibration, drop	Avoid excessive bumping in usage

Contactor & Electric Reply

Condition	Reason	Action	Cause	Correction
Non-stop activation	Junction welding burn out	Change contactor if continuous welding or burn out. For electric reply, visual inspection of junction		Do not over-operate
			Excessive voltage (Excessive current)	Operate under rated voltage
			Excessive current due to overload	Operation under rated voltage
No operation	Coil burning	Measure coil resistance value. Change coil if value infinite.		Avoid over-operation
			Excessive voltage	Operate under rated voltage
			Vibration due to low voltage (Starting current added continuous)	Operate under rated voltage
		Replace contactor if action is not smooth. For electric reply, visual inspection for part breakage	Vibration, drop	Avoid excessive bumping in usage

Limit Switch

Condition	Reason	Action	Cause	Correction
No operation (Contactor)	Contact fused	Operate limit switch. Check continuity of contactor, replace if result is negative	Limit switch overuse	Avoid overuse of switch
	Wire break	Inspect cable, change if wire breakage or replace limit switch	Vibration, drop	Avoid excessive bumping in usage
	Moveable parts rusting	Check movable parts such as limit lever. Remove if rusty or replace if adhesive	Set in Up/Down limit for long time	Do not set in Up/Down limit

Motor did not stop upon reaching upper and lower limit	Contact fused	Operate limit switch. Check continuity of contactor, replace if cannot stop	Limit switch used frequently	Avoid overuse of limit switch
	Rusting of moveable parts	Check movable parts such as limit lever. Remove if rusty or replace if adhesive	Infrequent usage; use in moist environments.	Regular inspection
	Wiring error	Reference wiring diagram. If limit switch cable is properly connected, it is inversely connected. Swap 2 wire power cords	Wiring error	Properly connect wire power cords as per wiring diagram

Push button switch

Condition	Reason	Action	Cause	Correction
No operation (Contactor)	Emergency button is pressed	Turn button right to recover	Emergency button not reset	Read User Manual before usage
	Switch gear fault	Conduction contacts, replace switch if off	Vibration, drop	Avoid excessive bumping in usage
	Wiring break	Check if button cable is correctly connected to switch device. Repair if broken	Vibration, drop	Avoid excessive bumping in usage
	Terminal screw loose	Tighten screw	Vibration, drop	Avoid excessive bumping in usage
	Button cable wire break	Replace cable or button cable when wire break	Cable coating damaged	Avoid contact with other equipment during operation
Faulty installation			Install protection line firmly	
Action does not correspond with display	Wiring error	Reference wiring diagram. If limit switch cable is properly connected, it is inversely connected. Swap 2 wire power cords	Wiring error	Properly connect wire power cords as per wiring diagram
Operation continues upon button release	Faulty switch gear part	Replace switch if not smooth.	Vibration, drop	Avoid excessive bumping in usage

Electric Shock

Condition	Reason	Action	Cause	Correction
Electric shock upon touching machinery or control switch	Equipment not properly grounded	Measure earth resistance. If below 100Ω assemble ground wire	Improper ground wire connection	Firmly connect ground wire
			Ground wire bad connection	Assemble carefully to prevent loose screw
			Cable break	Do not apply excessive force on cable
	Dampness/ water	Clean, use once dry	Wet hands	Do not operate with wet hands

Hook

Condition	Reason	Action	Cause	Correction
Hook mouth open	Hook deformation	Replace hook if deformation is beyond permitted range.	Overload	Operate under rated voltage
			Lifting (hook connected with grounded object)	Do not lift grounded objects.
			Load hanging on hook head; hook pull horizontal	Lifting load properly with hook
			Hanger suspension errors	Lifting angle must be controlled within 120 °
			Load size exceeds rated hook	Using proper hook
Hook twist			Chain wrapped around load	Do not wrap chain
Head hook improper rotating	Bearing rust, corrosion	Hand rotation; maintain or replace if experiencing difficulty rotating	Inadequate grease lubricant; corrosion	Apply grease lubricant regularly; prevent hook contamination of chemical agents
	Bearing damage		Dust	Prevent foreign matter from entering head

Load Chain

Condition	Reason	Action	Cause	Correction
Chain twist	Bottom hook upturned	Reset hook	Bottom hook rotation during usage	Check hook state before operation
	Chain twist in machinery body	Reassemble chain guide and load chain	Improper assembly	Ensure proper assembly
Limit switch suddenly activated in decline	Chain twist or knot in chain bag	Confirm chain bag capacity (chain bag nameplate) replace with larger one if capacity insufficient	Chain bag inadequate capacity	Confirm lifting height and chain bag capacity
Crackling sound	Chain damage	Measure wear of chain link diameter. Replace if reaching wear limit	Long-term operation with insufficient lubrication	Apply grease lubricant regularly
Irregular sound from springs (cracking sound)	Wear of link part	Measure diameter on wear of chain, and replace when at wear limit	Excessive operation	Avoid excessive operation
			Overload	Use under rated load
			Incline pull	Ensure proper pull direction
			Wear of load pulley and empty pulley	Refer to load pulley and empty pulley
	Extension of pitch	Measure pitch and replace when exceeding limit	Overload	Use under rated load
Irregular sound	Damage or deformation on chain surface	Replace when obvious damage and deformation occur	Use under transition situation	Use under models with multiple chain
	Mark on chain surface		Chain used improperly	Ensure proper assembly
			Damaged by other equipment	Monitor surrounding environment throughout usage to avoid collisions
Discoloration	Rust, corrosion	Apply lubricants and replace when obvious rust and corrosion occurs	Lubricant exhausted	Apply lubricating oil regularly
			Exposure to water	Use in dry places
			Influenced by seawater or chemical agent	Inform us if used in special circumstances to safeguard range
Load chain fractured	Reaching service life	Check chain, replace if differing from benchmark specifications	Mechanical life	Operate correctly and manage properly including inspection before usage and regular check-ups

Chain Wheel

Condition	Reason	Action	Cause	Correction
Improper noise	Wear of chain wheel	Check wear degree on chain, wheel slot, and load chain. Replace if badly worn	Long-term operation with insufficient lubrication	Apply lubricating oil regularly
			Excessive operation	Avoid excessive operation
			Overload	Use under rated load
			Incline pull	Avoid incline pull

Load pulley and empty pulley

Condition	Reason	Action	Cause	Correction
Irregular sound from springs (cracking sound)	Wear of pulley	Measure slot edge thickness and load chain, replace if badly worn	Long-term operation with insufficient lubrication	Apply lubricating oil regularly
			Excessive operation	Avoid excessive operation
			Overload	Use under rated load
			Incline pull	Avoid incline pull

Chain Guide

Condition	Reason	Action	Cause	Correction
Increased shaking	Wear of chain guide and guide pulley	Measure benchmark size and load chain, replace if badly worn and limit size exceeded	Incline pull	Avoid incline pull

Chain Wheel, Junction Part

Condition	Reason	Action	Cause	Correction
Unable to lift loads	Wear, breakage	Replace when obvious wear or breakage occur	Long-term operation with insufficient lubrication	Apply lubricating oil and inspect annually
			Long-term operation with insufficient lubrication (joint part of motor shaft)	Apply lubricating oil and inspect annually
Irregular operation	Wear, breakage		Limit switch used too frequently	Avoid excessive use of limit switch

Bearing

Condition	Reason	Action	Cause	Correction
Unable to lift loads	Breakage	Replace bearing	High temperature or high frequency	Avoid use at high temperatures or high frequency
Abnormal sound	Aging	Replace bearing		

Trolley

Condition	Reason	Action	Cause	Correction
No drive due to wheel skid	Rail tilt	Confirm rail slope is within 1 °	Improper rail settings	Set up orbit correctly
No drive due to wheel skid	Apply oil above orbit wheel tread.	Ensure wheel is clean and unobstructed	Use in environment which outside material does not interfere with parts	Clean orbit regularly
Audible friction when travelling on curve track	Friction resistance between wheel and rail	Apply lubricating oil on track tread		
No drive on curve track	Interference of curve track and trolley	Confirm that orbit curve's radius is minimal bending radius	Curve track exceeding limit value	Avoid use on curve track exceeding limit value
Wheel raised and unable to be driven	Inclined pull wheel raised		Operation method	Correct use
Wheels stopped revolving	Faulty gear connection	Ensure clean space between wheel and gear	Interference from outside material	Check regularly
Abnormal sound	Improper adjustment circle	Confirm adjustment circle number and insert position	Insufficient confirmation	Install correctly
	Wear of wheel	Confirm wear degrees	Travelling surface has bump	Confirm regularly
	Deformation of wheel	Check wheel bending and surface damage	Excessive collision, travelling surface deformed	Replace and use correctly
	Aging of wheel bearings	Confirm irregular sound exists when wheel rotates	Reaching service life	Replace
	Deformation and wear of track	Confirm rail wear and deformation	Overload or reaching service life	Replace and use correctly

Electric Trolley

Condition	Reason	Action	Cause	Correction
Wheels stopped revolving	Brake gelling	Open motor cover remove rust and dirt	Usage environment	Inspect regularly
	Electric fault	Refer to items of electric chain hoist		
Abnormal sound	Wear of edge guide wheel	Confirm wear degrees	Reaching service life	Confirm regularly
	Wear of friction slices	Confirm wear degrees of friction slices	Reaching service life	Confirm regularly

Manual Trolley

Condition	Reason	Action	Cause	Correction
Unable to move hand chain	Bad connection between hand wheel and hand chain	Properly adjust hand chain on hand wheel	Excessive or improper usage	Replace worn or deformed components

Chain Hoist

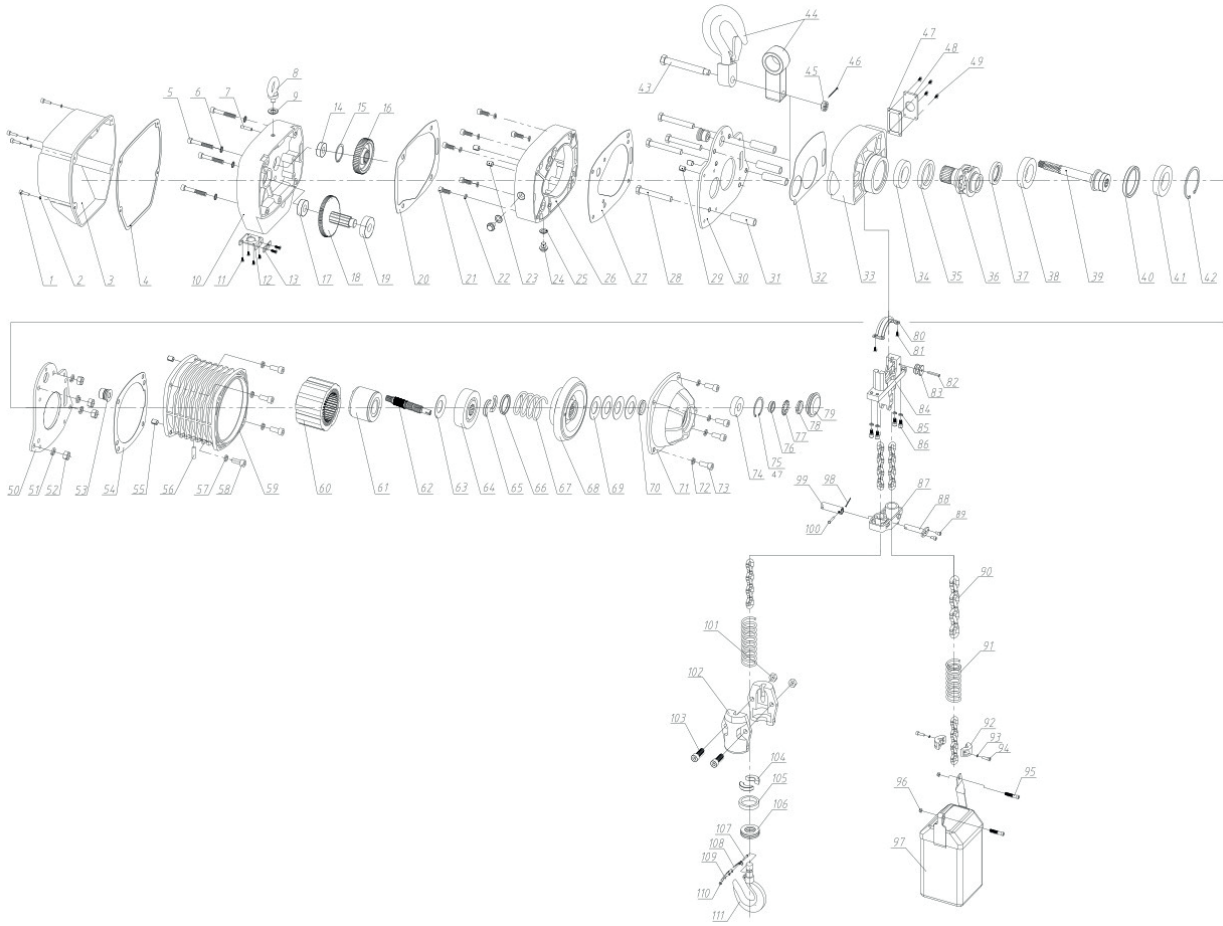

N°	DESCRIPTION	Q	N°	DESCRIPTION	Q	1N°	DESCRIPTION	Q
1	Hexagon Circular	4	38	Deep Groove	1	75	Internal Circlip	1
2	Spring Gasket	4	39	Output Shaft	1	76	Upper Gasket	1
3	Gearbox Base	1	40	Bearing Fixed	1	77	Locking Piece	1
4	Gasket Of Gearbox	1	41	Deep Groove	1	78	Screw Cap	1
5	Hexagonal Circular	4	42	Internal Circlip	1	79	Rubber Cover	1
6	Serrated Gasket	4	43	Hexagonal Bolt	1	80	Guide Sheet Iron	1
7	Gearbox Base	1	44	Ring	1	81	Notch Countersink	2
8	Lifting Eyebolt	1	45	Up Hook	1	82	Pulley Axle	1
9	Lifting Eyebolt	1	46	Cotter Pin	1	83	Guide Pulley	1
10	Gearbox	1	47	Side Cover	1	84	Chain Guide	1
11	Notch Countersink	6	48	Side Cover	1	85	Spring Gasket	4
12	Wiring Fix Ring	1	49	Hexagonal	4	86	Hexagonal Circular	4
13	Wiring Fix Ring	1	50	Base plate of	1	87	Guide Bracket	1
14	Deep Groove Ball	1	51	Spring Gasket	4	88	Stop Pin Assembly	1
15	Washer on Shaft	1	52	Nut	4	89	Hexagonal Circular	2
16	Outpu Gear	1	53	Bushing	2	90	Chain	7pcs
17	Deep Groove Ball	1	54	Motor Case	1	91	Limit Spring	2
18	Gear-gear Shaft	1	55	Fitting Pin	2	92	Chain Limit ring	2
19	Deep Groove Ball	1	56	Hexagonal awl	1	93	Spring Gasket	4
20	Gearbox Basket	1	57	Spring Gasket	4	94	Hexagonal Circular	2
21	Hexagonal Circular	6	58	Hexagonal	4	95	Hexagonal Circular	2
22	Spring Gasket	6	59	Motor Case	1	96	Hexagonal Nut	2
23	Fitting Pin	2	60	Motro Stator	1	97	Chain Bag Assembly	1
24	Hex Bolt	2	61	Motor Rotor	1	98	Cotter Pin	1
25	Hex Bolt Gasket	2	62	Motro Axle	1	99	Connection Shaft	1
26	Middle Pieces	1	63	Disc Spring	1	100	Pin Roll	1
27	Middle Pieces	1	64	Guide Block	1	101	Hexagonal Nut	2
28	Panel Bolts	4	65	Two-piece Ring	2	102	Single Back-Hooking	1
29	Fitting Pin	2	66	Fixing Ring	1	103	Hexagonal Circular	2
30	Gearbox Base	1	67	Brake Spring	1	104	Hook Two-piece	7Pairs
31	Connection Joint	4	68	Brake Assembly	1	105	Hook Fixing Ring	1
32	Connection Box	1	69	Disc Spring	4	106	Mono Directional	1
33	Connection Box	1	70	Rotor Gasket	1	107	Cross Recess Head	1
34	Deep Groove Ball	1	71	Rotor Gasket	1	108	Hook Spring	1
35	Oil Seal	1	72	Spring Gasket	4	109	Safety Piece	1
36	Chain Wheel	1	73	Hexagonal Circular	4	110	Hexagonal Nut	1
37	Oil Seal	1	74	Deep Groove Ball	1	111	Bottom Hook	1

Trolley

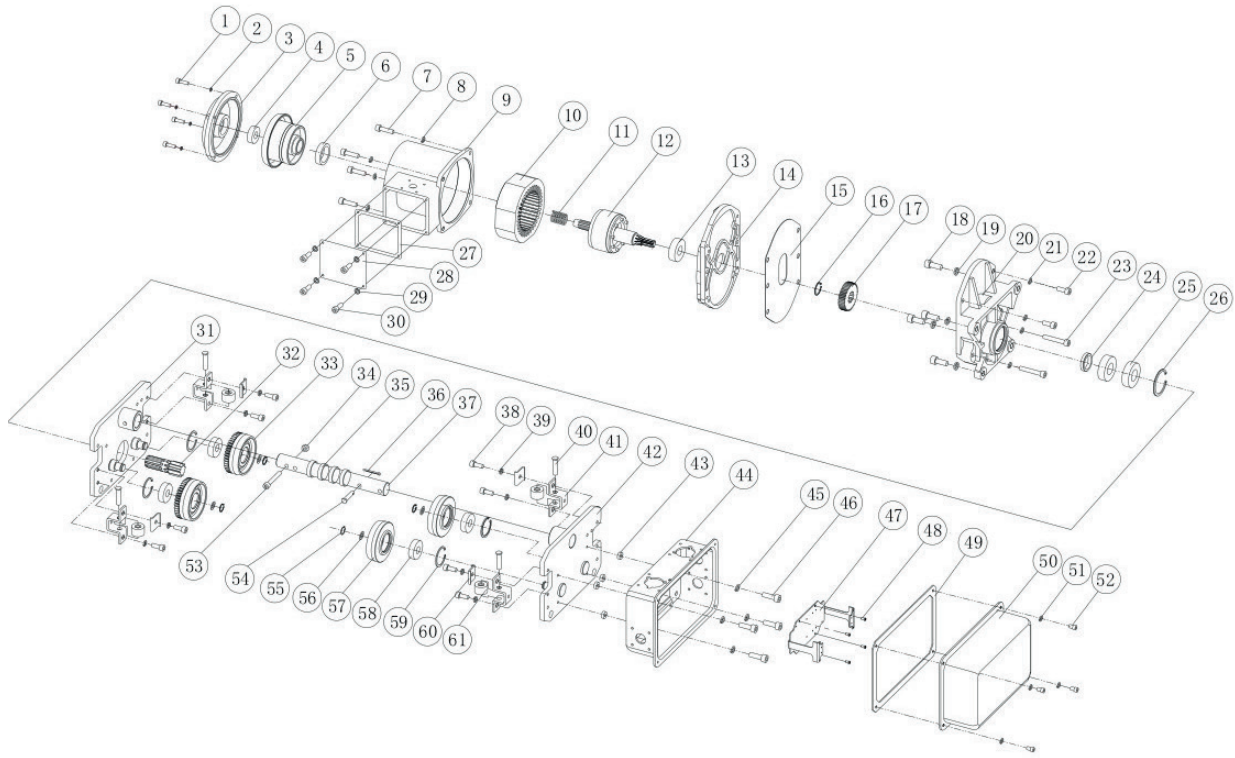

Quantity for each type of trolley

Nº	DESCRIPTION	Q	1t	2t	3t	5t	7.5t	10t
1	Hexagon Socket head cap screws	4	4	4	4	4	4	4
2	Grower Washer	4	4	4	4	4	4	4
3	Motor End Cover	1	1	1	1	1	1	1
4	Deep Groove Ball Bearing	1	1	1	1	1	1	1
5	Brake Block	1	1	1	1	1	1	1
6	Rubber Retainer Ring	1	1	1	1	1	1	1
7	Hexagon Socket Head Cap screws	4	4	4	4	4	4	4
8	Grower Washer	4	4	4	4	4	4	4
9	Motor Shell	1	1	1	1	1	1	1
10	Motor Stator	1	1	1	1	1	1	1
11	Brake Spring	1	1	1	1	1	1	1
12	Rotor Block	1	1	1	1	1	1	1
13	Depp Groove Ball Bearing	1	1	1	1	1	1	1
14	Motor Bottom Plate	1	1	1	1	1	1	1
15	Moot Bottom Plate Washer	1	1	1	1	1	1	1
16	Axle Retainer Ring	1	1	1	1	1	1	1
17	Gear	1	1	1	1	1	1	1
18	Hexagon Socket Head capScrew	4	4	4	4	4	4	4
19	Grower Washer	4	4	4	4	4	4	4
20	Gear Box	1	1	1	1	1	1	1
21	Grower Washer	2	2	2	2	2	2	2
22	Hexagon Socket Head Cap Screw	2	2	2	2	2	2	2
23	Hexagon Socket Head Cap Screw	2	2	2	2	2	2	2
24	Retainer Ring	1	1	1	1	1	1	1
25	Deep Groove Ball Bearing	2	2	2	2	2	2	2
26	Hole Retainer Ring	1	1	1	1	1	1	1
27	Motor Side Plate Washer	1	1	1	1	1	1	1
28	Motor Side Plate	1	1	1	1	1	1	1
29	Grower Washer	4	4	4	4	4	4	4
30	Hexagon Socket Head Cap Screw	4	4	4	4	4	4	4
31	Trolley Main Support Plate Block	1	1	1	1	1	1	1
32	Castellated Shaft	1	1	1	1	1	1	1
33	Driven Tooth Gear	2	2	2	2	2	2	2
34	Luck Nut	1	1	1	1	1	1	1

N°	DESCRIPTION	Q	1t	2t	3t	5t	7.5t	10t
35	Axle Adjusting Ring	8	8	8	8	8	8	8
36	Cutter Pin	1	1	1	1	1	1	1
37	Axle	1	1	1	1	1	1	1
38	Hexagon Socket Head Cap Screws	8	8	8	8	8	8	8
39	Glomer Washer	8	8	8	8	8	8	8
40	Side Wheel Axle	4	4	4	4	4	4	4
41	Side Wheel Support	4	4	4	4	4	4	4
42	Trolley Subplate Block	1	1	1	1	1	1	1
43	Washer For Wire Shell	4	4	4	4	4	4	4
44	Bottom Block Of Motor Wire	1	1	1	1	1	1	1
45	Grower Washer	4	4	4	4	4	4	4
46	Hexagon Socket Head cap	4	4	4	4	4	4	4
47	Fixed Pin	1	1	1	1	1	1	1
48	Phillips Screw	4	4	4	4	4	4	4
49	Washer For Wire Shell	1	1	1	1	1	1	1
50	Motor Wire Shell	1	1	1	1	1	1	1
51	Grower Washer	4	4	4	4	4	4	4
52	Hexagon Socket Head cap Screw	4	4	4	4	4	4	4
53	Hexagon Socket Head cap Screw	1	1	1	1	1	1	1
54	Fixed Pin	1	1	1	1	1	1	1
55	Axle Retainer Ring	4	4	4	4	4	4	4
56	Wheel Retainer Ring	4	4	4	4	4	4	4
57	Wheel	2	2	2	2	2	2	2
58	Deep groove ball bearing	4	4	4	4	4	4	4
59	Hole Retainer Ring	4	4	4	4	4	4	4
60	Side Wheel Support Washer	4	4	4	4	4	4	4
61	Trolley Side Wheel	4	4	4	4	4	4	4

PWR_M5 ELECTRIC CHAIN

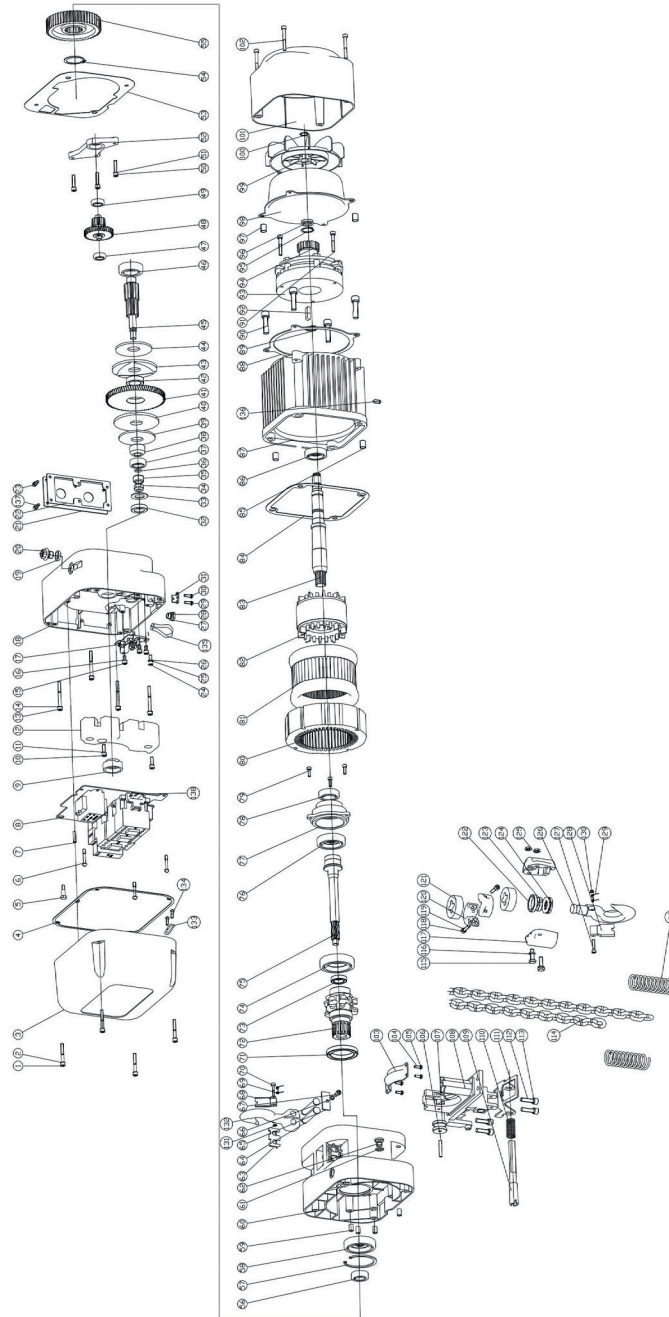

N°	DESCRIPTION	Q	70N°	DESCRIPTION	Q
1	Hexagonal Circular Bolt	4	37	Deep Groove Ball Bearing	1
2	Spring Gasket	4	38	Pressing Cover	1
3	Gearbox Base Cover	1	39	Disc Spring	1
4	Gasket of Gear Base	1	40	Brake Disk	1
5	Panel Pin	1	41	Middle-gear	1
6	Slotted pan head screw with waidsted shank	3	42	Sleeve of middle gear	1
7	Fitting Pin	1	43	Brake Disk	1
8	Installing Panel of electronics	1	44	Disc Spring	1
9	Nut Cap	1	45	Clutch Shaft	1
10	Hexagonal Circular Bolt	2	46	Deep groove ball bearing	1
11	Spring Gasket	2	47	Deep groove ball bearing	1
12	Balance Block	1	48	Duplex Gear	1
13	Hexagonal Circular Bolt	4	49	Deep Groove Ball Bearing	1
14	Gasket Of Screw	4	50	Hexagonal Circular Bolt	3
15	Hexagonal Circular Bolt	3	51	Spring Basket	3
16	Spring Gasket	3	52	Fixed Bracket reduction	1
17	Limit Switch Assembly	1	53	Gasket Of GearBox	1
18	Gearbox	1	54	Shaft Ring A	1
19	Gasket Of Bolt	1	55	Output Gear	1
20	Hexagon Bolt	1	56	Deep Groove Ball Bearing	1
21	Side Cover	1	57	Shaft Ring B	1
22	Side Cover Gasket	3	58	Deep Groove Ball Bearing	1
23	Hexagonal Circular Bolt	6	59	Fitting Pin	2
24	Hexagonal Circular Bolt	1	60	Connection Box	1
25	Spring Gasket	1	61	Gasket Of Hexagonal Nut	1
26	Flat Gasket	1	62	Hexagonal Nut	1
27	Hexagon Bolt	2	63	Block Of Piece Upper Hook Pin	1
28	Gasket Of Hexagon Bolt	2	64	Upper Hook Pin	1
29	Cross Recess Head Screw	2	65	Pressing Plate Of Upper Hook	
30	Spring Gasket	2	66	Spring Gasket	1
31	Wire Clamp	1			
32	Oil Seal	1			
33	Waveform Spring Gasket	1			
34	Hexagonal Nut	1			
36	O-ring	1			

1N°	DESCRIPTION	Q
67	Hexagonal Circular Bolt	1
68	Hook Latch	1
69	Hook Spring	1
35	Shaft Sleeve Of Clutch	1
71	Oil Seal	1
72	Chain Wheel	1
73	Oil Seal	1
74	Deep Groove Ball Bearing	1
75	Output Shaft	1
76	Deep Groove Ball Bearing	3
77	Sleeve Motro Shaft	1
78	Deep Groove Ball Bearing	1
79	Hexagonal Circular Bolt	3
80	Motor Stator	1
81	Motor Wire Cooling	1
82	Motor Rotor	1
83	Motor Shaft	1
84	Motor Case Gasket	1
85	Fitting Pin	2
86	Deep Groove Ball Bearing	1
87	Motor Case	1
88	Gasket O f Brake Cover	1
89	Shaft Ring A	1
90	Hexagonal Circular Bolt	4
91	Hexagonal Circular Bolt	3
92	Flat Key	2
93	Brake Block	1
94	Splined Hub Of Brake	1
95	Shaft Ring A	1
96	V-Ring	1
97	Fitting Pin	2
98	Brake Cover	1
99	Cooling Fan	1
100	Shaft Ring A	1
101	Fan Cover	1
102	Hexagonal Circular bolt	4
103	Guide Sheet Iron	1
104	Cross Recess Head Screw	4

1N°	DESCRIPTION	Q
105	Spring Gasket	4
70	Cross Recess Head Screw	1
106	Guide Roller Axle	1
107	Guide Roller	1
108	Chain Guide	1
109	Connecting Shaft Of Limit Switch	1
110	Spring Of Limit Switch	1
111	Bracket Of Limit Switch	1
112	HexagonalCircular bolt	4
113	Spring Basket	4
114	Load Chain	1
115	Hexagonal Nut	2
116	Spring Basket	2
117	Bottom Hook Half Piece	2
118	Hexagonal Circular Bolt	2
119	Spring Basket	2
120	Chain Limit Ring	2
121	Limit Block	2
122	Hook Fixing Ring	1
123	Hook Piece Ring	2
124	Monodirectional Ball Bearing	1
125	Hexagonal Nut	1
126	Bottom Hook	1
127	Cross Recess Head Screw	1
128	Hook Latch	1
129	Hook Sping	1
130	Hexagonal Bolt	1
131	Hexagonal Bolt	1
132	Upper Hook	1
133	Fixing Ring	1
134	Cross Recess Head Screw	2
135	Sling	1
136	Hexagon Socket Set Screw With Cone Point	1
137	Spring Gasket	6
138	Wiring Strip	1
139	Limit Spring	2

1N°	DESCRIPTION
71	Flat key
72	Tripping spring
73	Stop collar A
74	Disc spring
75	Disc spring
76	Stator set
77	Brake set
78	Ball bearing
79	Shaft sleeve
80	Motor cover
81	Spring washer
82	Socket cap screw
83	Stop collar B
84	Hole elastic collar
85	Thrust washer
86	Round nut
87	Fan blade
88	Socket cap screw
89	Elastic collar
90	Cover
91	Housing plug set(1)
92	Guy clip
93	Power cord
94	Patera
95	Housing plug set(2)
96	Pushbutton cable set
97	Pushbutton switch set
98	Protecting hood
99	Guide wheel
100	Cylindrical pin
101	Chain guide holder
102	Spacing axis(2)
103	Guiding inlet(B)
104	Spacing spring

1N°	DESCRIPTION
105	Guiding inlet(A)
106	Chain guiding inlet plate
107	Socket cap screw
108	Chain
109	Compensating spring
110	Chain buckle
111	Socket cap screw
112	Spring washer
113	Flat washer
114	Loose pulley box(left)
115	Ball bearing
116	Loose pulley axis
117	loading semicircular ring
118	Thrust bearing
119	Hook
120	Loose pulley
121	Ball bearing
122	Loose pulley box(right)
123	Nut
124	Chain
125	Compensating spring
126	Lifting lug(2)
127	Phillips screw
128	Binder plate
129	Chain bucklet set
130	Tray entrance
131	Thin locknut
132	Phillips screw
133	Lifting lug(1)

The cooling fin is specially designed to ensure quick heat dissipation with the rate up to 40% of continuous service. The integral enclosed structure with IP55 protection grade makes it applicable for hostile environments.

The loading support frame consists of two steel plates and its shell is made of light aluminum, achieve a lightweight and resistant structure.

Inverse phase sequence protecting device which controls the circuit and disables operation in case the power supply is wrongly connected.

Electromagnetic brake system design allows instant brake as soon as the electric power is cut off.

Electromagnetic contactor can be used safely under high frequency. Low voltage controller to avoid unexpected accidents caused by electric leakage.

Upper and lower limit switches ensures the equipment life expectancy and avoid accidents.

High precision gears level 8

Low voltage pendant control (24V / 36V / 48V) with IP66 protection grade. Includes emergency stop and safety buttons.

G100 Chain can be safely used in hostile environments such as rain sea water and chemicals.

Forged safety hook 360 rotation.

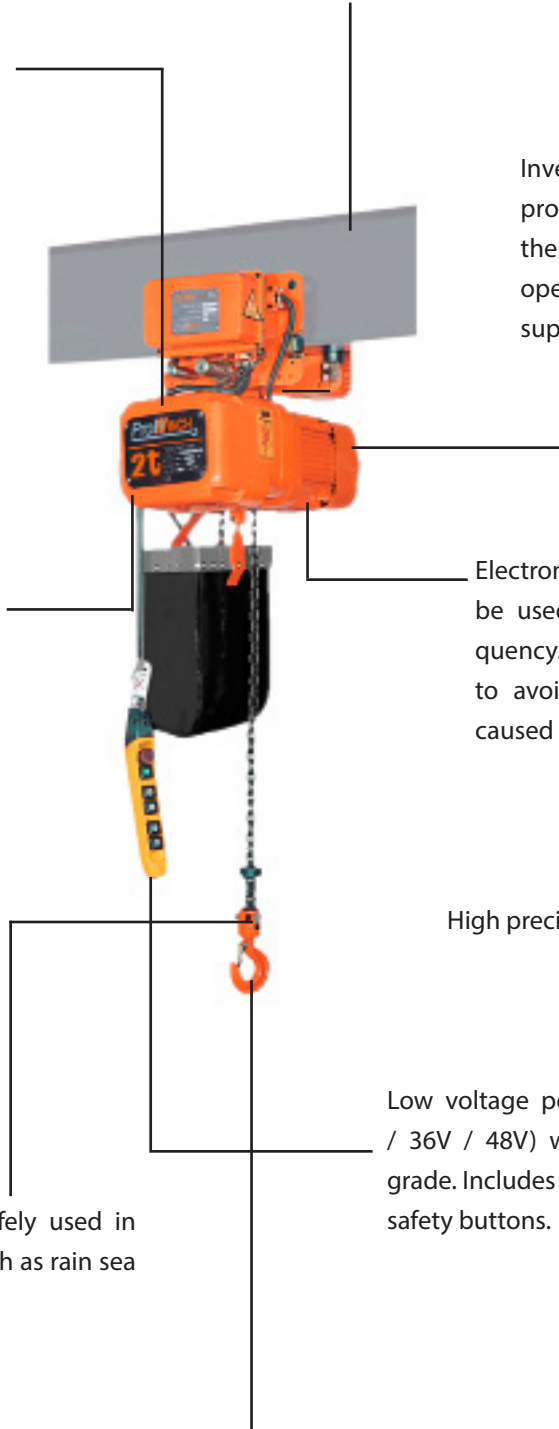

**PWR
Electric Chain Hoist**



SINGLE SPEED

		Code	PWR05	PWR1	PWR2	PWR3	PWR5	PWR10	PWR20	
HOIST	Capacity	Lb	1.100	2.200	4.400	6.600	11.000	22.000	44.000	
	Lifting Speed	Ft/Min	23,6	21,6		17,7	8,8		4	
	Lifting Height	Ft	23,6							39
	Motor Power	kW	0,8	1,5	3			3.0 x 2	2 x 3	
	Voltage	V	220~240/380/440~480V 50/60Hz 3 Phase							
	Motor Speed	RPM	1728@60Hz 1440@50HZ							
	Insulation Grade	Grade	F							
	Chain Type	Grade	G100							
	Chain Size	mm	6.3 x 19	7.1 x 21	10 x 30	11.2 x 34			11.2 x 34	
	Chain Falls	U	1				2	4	8	
Chain Length	Ft/m	30 ft / 9 m				60 / 18	160 / 48.5	320 / 9		
GENERAL	Operation Temperature	F°	-4°~ 104°F							
	Operating Humidity	%	<85%							
	Noise Level	dB	81							
	Control Voltage	V	24V / 36V / 48V							
	Weight	Lb	94	155	242	273	361	928	1.062	
	Dutty Class	FEM/ISO	H3/M4/1Am/Class C							
Standards		ASME HST-1 , ASME B30.16 , EN14492-2 , EN60204-32								

PWR Electric Chain Hoist



DUAL SPEED

		Code	PWR05i	PWR1i	PWR2i	PWR3i	PWR5i	PWR10i	PWR20i	
CHAIN HOIST	Capacity	Lb	1.100	2.200	4.400	6.600	11.000	22.000	44.000	
	Lifting Speed	Ft/Min	23,6	21,6		17,7	8,8		4	
	Lifting Height	Ft	23,6						39	
	Motor Power	kW	0,8	1,5	3			3.0 x 2	2 x 3	
	Voltage	V	220~240/380/440~480V 50/60Hz 3 Phase							
	Motor Speed	RPM	1728@60Hz 1440@50HZ							
	Insulation Grade	Grade	F							
	Chain Type	Grade	G100							
	Chain Size	mm	6.3 x 19	7.1 x 21	10 x 30	11.2 x 34			11.2 x 34	
	Chain Falls	U	1				2	4	8	
Chain Length	Ft/m	30 ft / 9 m					60 / 18	160 / 48.5	320 / 9	
GENERAL	Operation Temperature	F°	-4°~ 104°F							
	Operating Humidity	%	<85%							
	Noise Level	dB	81							
	Control Voltage	V	24V / 36V / 48V							
	Weight	Lb	94	155	242	273	361	928	1.062	
	Dutty Class	FEM/ISO	H3/M4/1Am/Class C							
Standards		ASME HST-1 , ASME B30.16 , EN14492-2 , EN60204-32								

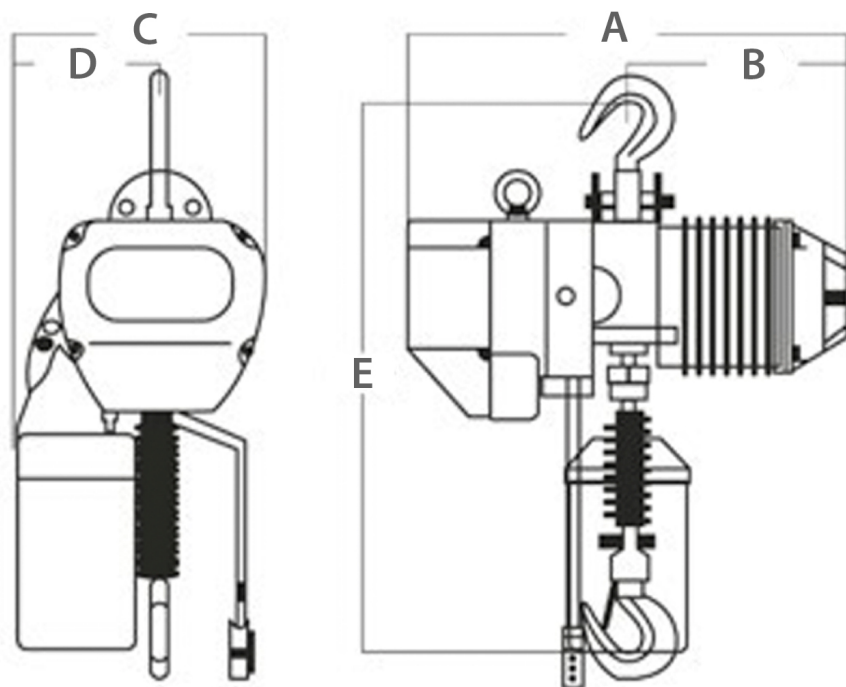

Dimensions in mm / Dimensiones en mm

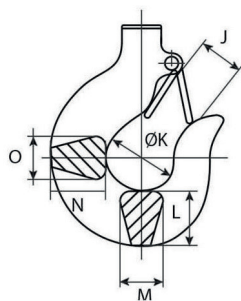

Dimensions	Model	PWR05	PWR1	PWR2	PWR3	PWR5	PWR10	PWR20	
	A	460	520	615	615	615	630	630	
	B	230	260	295	295	295	315	315	
	C	288	300	430	430	430	890	740	
	D	178	176	265	265	325	445	445	
	E	530	650	800	845	1.030	1.400	1.320	
	F	mm		32	40	48	48	80	88
	G			42	49	59	60	85	85
	H			30	39	49	57	80	80
	I			24	30	34	44	48	48
	J			34	46	56	67	82	82
K			24	29	35	43	55	55	

Dimensions	Model	PWR05i	PWR1i	PWR2i	PWR3i	PWR5i	PWR10i	PWR20i	
	A	460	520	615	615	615	630	630	
	B	230	260	295	295	295	315	315	
	C	288	300	430	430	430	890	740	
	D	178	176	265	265	325	445	445	
	E	530	650	800	845	1.030	1.400	1.320	
	F	mm		32	40	48	48	80	88
	G			42	49	59	60	85	85
	H			30	39	49	57	80	80
	I			24	30	34	44	48	48
	J			34	46	56	67	82	82
K			24	29	35	43	55	55	

SERVICE	> Load	>Time	Maintenance (Months)
NORMAL	<65%	< 25%	6~ 12
HEAVY	<65%	>25%	3 ~ 6
SEVERE	 Abnormal conditions Enviromental, geographical and/or risk <100% <Duty Cicle Limit		1 ~ 3

**PWRC
Electric Chain Hoist**



SINGLE SPEED

HOIST
TROLLEY
CHAIN
GENERAL

Code		PWRC05	PWRC1	PWRC2	PWRC3	PWRC5	PWRC7	PWRC10	PWRC20
Capacity	Lb	1.100	2.200	4.400	6.600	11.000	16.000	22.000	44000
Lifting Height	Ft	20	20		17.7	8.8	5.9	40	40 ft
Motor Power	kW	1728@60Hz 1440@50HZ							
Voltage	V	220~240/440~480V 60Hz 3 Phase							
Insulation Grade	Grade	F							
Trolley Speed	Ft/Min	36	68.8			36.0			
Trolley Power	kW	0.4	0.4			0.8			
I- Beam Width	mm	52 - 153		3.22 - 6.91	3.9 - 6.91			100-178	
Min Turn Radius	Ft	2.6	2.62	2.95	3.28	4.92	5.90	6.6	4.9
Chain Type	Grade	G100							
Chain Dimensions	ft	6.3 x 19	7.1 x 21	10 x 30	11.2 x 34				
Chain falls	u	1			2	3	4	8	
Chain Length	Ft	20			59	88	160	320	
Operation Temperature	F	-4 ~ 104° F							
Operating Humidity	%	<85%							
Noise Level	dB	81.0							
Control Voltage	V	24 V							
Weight (*)	lb	183	227	355	368	485	798	1.888	2.123
Dutty Class	FEM/ISO	H3/M4/1Am/Class C							
Standards		ASME HST-1 . ASME B30.16 . B30.17 . EN14492-2 . EN60204-32							

**PWRC
Electric Chain Hoist**

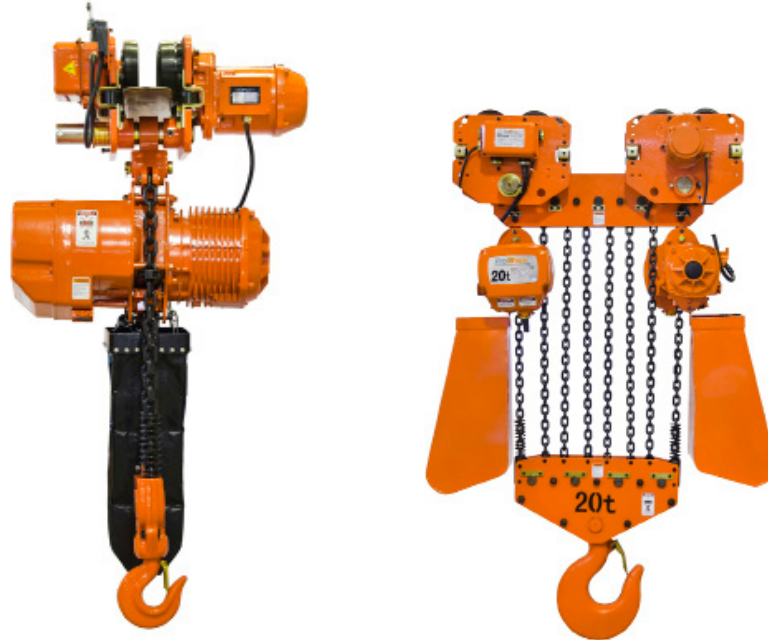

DUAL SPEED

HOIST

TROLLEY

CHAIN

GENERAL

Code		PWRC05i	PWRC1i	PWRC2i	PWRC3i	PWRC5i	PWRC7i	PWRC10i	PWRC20i
Capacity	Lb	1.100	2.200	4.400	6.600	11.000	16.000	22.000	44000
Lifting Height	Ft	20	20		17.7	8.8	5.9	40	40 ft
Motor Power	kW	1728@60Hz 1440@50HZ							
Voltage	V	220~240/440~480V 60Hz 3 Phase							
Insulation Grade	Grade	F							
Trolley Speed	Ft/Min	36	68.8			36.0			
Trolley Power	kW	0.4	0.4			0.8			
I-Beam Width	mm	52 - 153		3.22 - 6.91	3.9 - 6.91			100-178	
Min Turn Radius	Ft	2.6	2.62	2.95	3.28	4.92	5.90	6.6	4.9
Chain Type	Grade	G100							
Chain Dimensions	ft	6.3 x 19	7.1 x 21	10 x 30	11.2 x 34				
Chain falls	u	1				2	3	4	8
Chain Length	Ft	20				59	88	160	320
Operation Temperature	F	-4 ~ 104° F							
Operating Humidity	%	<85%							
Noise Level	dB	81.0							
Control Voltage	V	24 V							
Weight (*)	lb	183	227	355	368	485	798	1.888	2.123
Dutty Class	FEM/ISO	H3/M4/1Am/Class C							
Standards		ASME HST-1 . ASME B30.16 . B30.17 . EN14492-2 . EN60204-32							



7,5 Tons



7,5 Tons

WARRANTY

3 Years / Certification valid for 1 year
 10 Years parts and service availability

SERVICE	> Load	>Time	Maintenance (Months)
NORMAL	<65%	< 25%	6~ 12
HEAVY	<65%	>25%3	3 ~ 6
SEVERE	Abnormal conditions Enviromental, geographical and/or risky <100% <Duty Cicle Limit		1 ~ 3

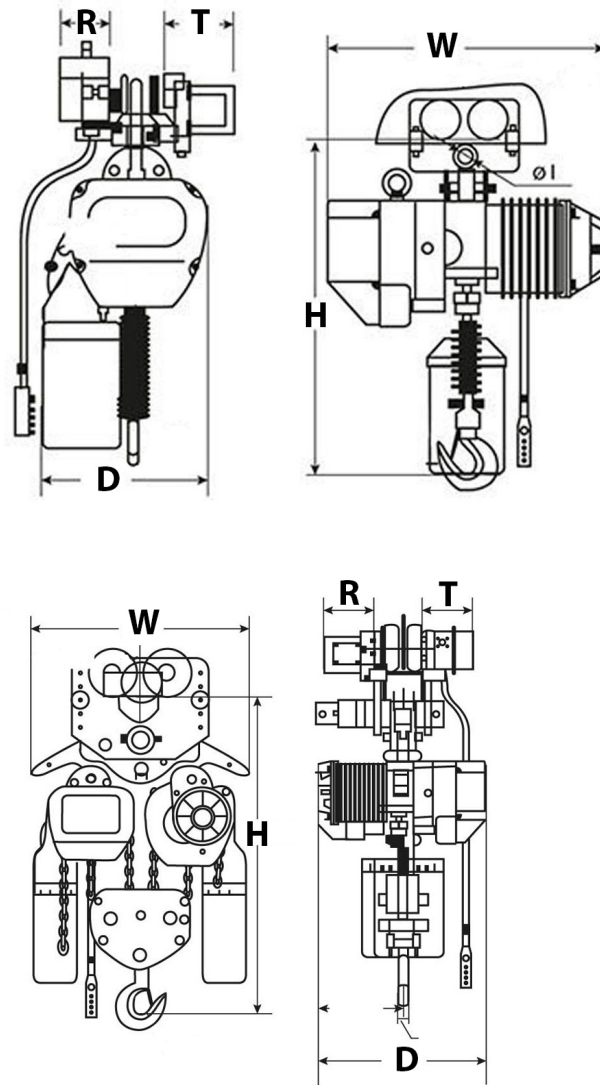

Dimensions

Model		PWRC1	PWRC2	PWRC3	PWRC5	PWRC7	PWRC10	PWRC20
T	in	9.09	9.09	9.09	9.09	9.09	9.09	9.09
H		25.5	30.5	33	40	48	55	58
W		20.5	24.5	24	24	24	25	25
R		5.5	5.5	5.5	5.5	5.5	5.5	5.5
D		12	17	17	17	20	35	50

- T. Trolley Motor Width
- H. Trolley minimum Headroom
- W. Width
- R. Trolley
- D. Depth

**PWR_M5
Electric Chain Hoist**



SINGLE SPEED

		PWR1M5	PWR2M5	PWR3M5	PWR5M5	
HOIST	Code					
	Capacity	Lb	2.200	4.400	6.600	11.000
	Lifting Speed	Ft/Min	20 ft/6min	27.5ft /8.2m	2.5 - 7.5 m/min	13ft/4m
	Lifting Height	Ft	23.6	20 ft / 6m	26 ft / 8m	30 ft / 9 m
	Motor Power	kW	1.5	3	3	3
	Voltage	V	220~240/380/440~480V 50/60Hz 3 Phase			
	Motor Speed	RPM	1728@60Hz 1440@50HZ			
	Insulation Grade	Grade	F			
	Chain Type	Grade	G80			
	CHAIN	Chain Dimensions	mm	7.1 x 21	10 x 30	11.2 x 34
Chain Falls		U	1			
Chain Length		Ft	30 ft / 9 m			
Operation Temperature		F°	-4°~ 104°F			
GENERAL	Operating Humidity	%	<85%			
	Noise Level	dB	81			
	Control Voltage	V	24V			
	Weight	Lb	147	255	282	357
	Dutty Class	FEM/ISO	H4/M5/2m/Class D			
	Standards		ASME HST-1 , ASME B30.16 , EN14492-2 , EN60204-32			

PWR_M5i Electric Chain Hoist



DUAL SPEED

		PWR1M5i	PWR2M5i	PWR3M5i	PWR5M5i	
HOIST	Code					
	Capacity	Lb	2.200	4.400	6.600	11.000
	Lifting Speed	Ft/Min	20 ft/6min	27.5ft /8.2m	2.5 - 7.5 m/min	13ft/4m
	Lifting Height	Ft	23.6	20 ft / 6m	26 ft / 8m	30 ft / 9 m
	Motor Power	kW	1.5	3	3	3
	Voltage	V	220~240/380/440~480V 50/60Hz 3 Phase			
	Motor Speed	RPM	1728@60Hz 1440@50HZ			
	Insulation Grade	Grade	F			
	Chain Type	Grade	G80			
	Chain Dimensions	mm	7.1 x 21	10 x 30	11.2 x 34	
CHAIN	Chain Falls	U	1			
	Chain Length	Ft	30 ft / 9 m			
	Operation Temperature	F°	-4°~ 104°F			
GENERAL	Operating Humidity	%	<85%			
	Noise Level	dB	81			
	Control Voltage	V	24V			
	Weight	Lb	147	255	282	357
	Dutty Class	FEM/ISO	H4/M5/2m/Class D			
	Standards		ASME HST-1 , ASME B30.16 , EN14492-2 , EN60204-32			

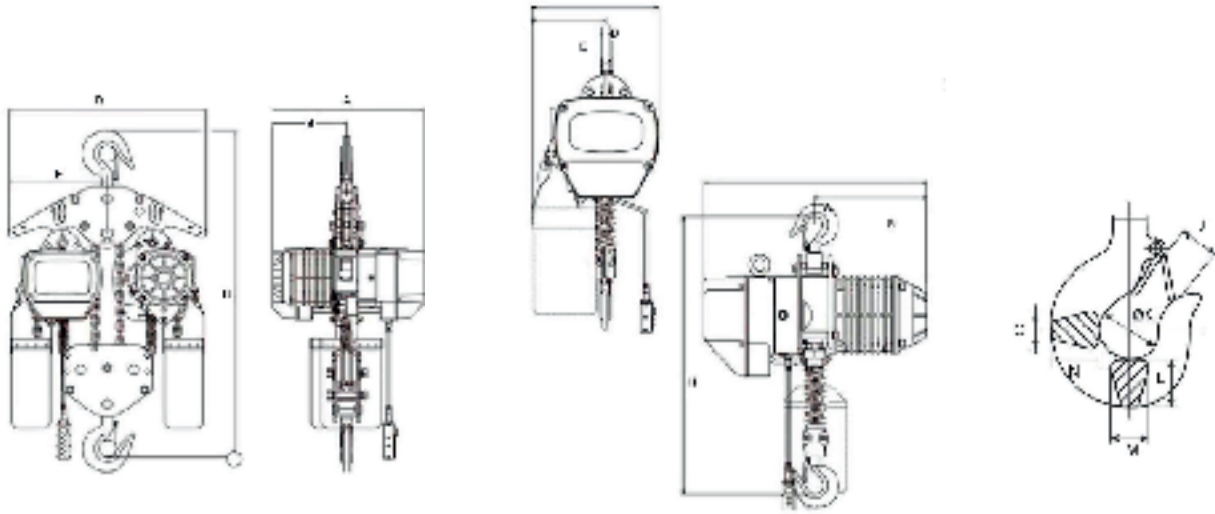

Dimensions

Model		PWR1M5	PWR2M5	PWR3M5	PWR5M5
H	mm	16 in / 410 mm	24 in / 615 mm	24 in / 615 mm	33 in / 845 mm
W		24 in / 620 mm	29 in / 745 mm	29 in / 745 mm	29 in / 745 mm
D		12 in / 295 mm	17 in / 420 mm	17 in / 420 mm	17 in / 420 mm
J		1.3 in / 34 mm	1.6 in / 40 mm	1.9 in / 48 mm	1.9 in / 48 mm

Dimensions

	PWR1M5i	PWR2M5i	PWR3M5i	PWR5M5i
	16 in / 410 mm	24 in / 615 mm	24 in / 615 mm	33 in / 845 mm
	24 in / 620 mm	30 in / 745 mm	30 in / 745 mm	30 in / 745 mm
	12 in / 295 mm	17 in / 420 mm	17 in / 420 mm	17 in / 420 mm
	1.3 in / 34 mm	1.6 in / 40 mm	1.9 in / 48 mm	1.9 in / 48 mm

SERVICE	> Load	>Time	Maintenance (Months)
NORMAL	<65%	< 25%	6~ 12
HEAVY	<65%	>25%3	3 ~ 6
SEVERE	 Abnormal conditions Enviromental, geographical and/or risky <100% <Duty Cicle Limit		1 ~ 3

The cooling fin is specially designed to ensure quick heat dissipation with the rate up to 40% of continuous service. The integral enclosed structure with IP55 protection grade makes it applicable for hostile environments.

The loading support frame consists of two steel plates and its shell is made of light aluminum, achieve a lightweight and resistant structure.

Inverse phase sequence protecting device which controls the circuit and disables operation in case the power supply is wrongly connected.

Electromagnetic brake system design allows instant brake as soon as the electric power is cut off.

Electromagnetic contactor can be used safely under high frequency. Low voltage controller to avoid unexpected accidents caused by electric leakage.

Upper and lower limit switches ensures the equipment life expectancy and avoid accidents.

High precision gears level 8

G100 Chain can be safely used in hostile environments such as rain sea water and chemicals.

Low voltage pendant control (24V / 36V / 48V) with IP66 protection grade. Includes emergency stop and safety buttons.

Forged safety hook 360 rotation.

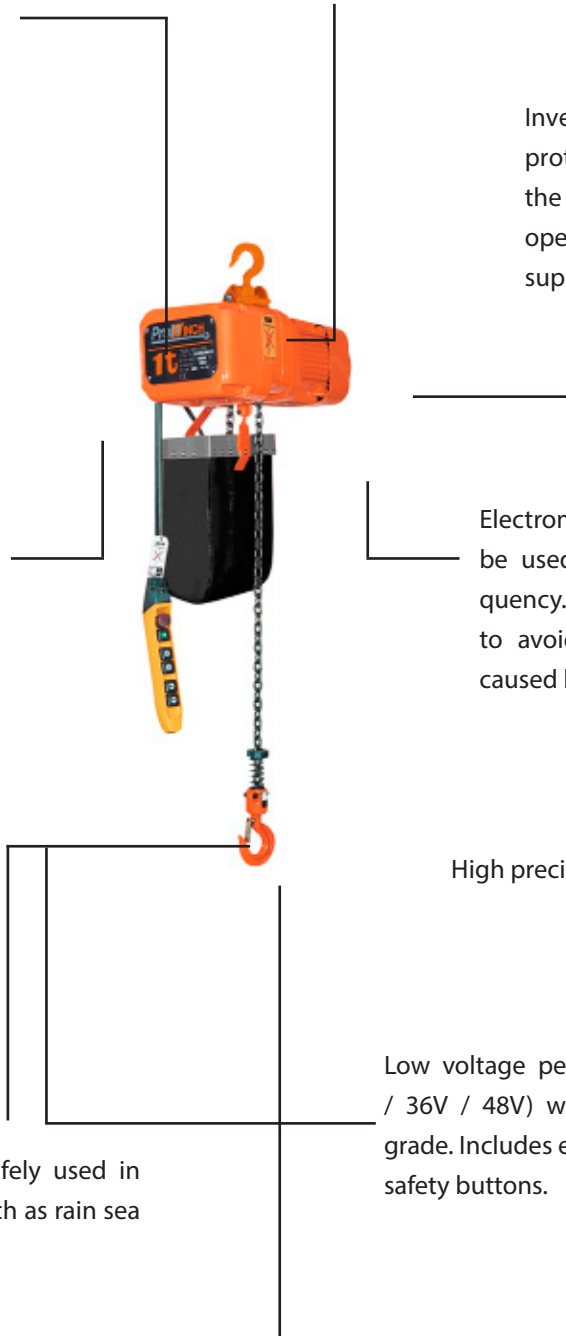

PWRC_M5



SINGLE SPEED

		Code	PWRC1M5	PWRC2M5	PWRC3M5	PWRC5M5
HOIST	Capacity	Lb	2.200	4.400	6.600	11.000
	Lifting Height	Ft	20 ft / 6 m	17.7 - 5.9	8.8 - 2.9	5.9 - 1.9
	Motor Power	kW	1.5 kW	3 kW	3kW	3kW
	Voltage	V	220~240/380/440~480V 50/60Hz 3 Phase			
	Motor Speed	RPM	2.880 / 960			
	Insulation Grade	Grade	F			
CHAIN	Chain Size	mm	7.1 x 21	10 x 30	11.2 x 34	
	Control		Pendant Control and Optional Wireless			
	Control Voltage		24V			
	Chain Length	Ft	20 ft / 6 m			30 ft / 9 m
GENERAL	Operation Temperature	F	-4 ~ 104° F / -20 ~ 40° C			
	Operating Humidity	%	<85%			
	Noise Level	dB	81			
	Control Voltage	V	24			
	Weight (*)	lb	220	385	443	544
	Dutty Class	FEM/ISO	H3/M4/1Am/Class C			
Standards		ASME B30.16 / ASMEB30.17 / ANSIZ535.4 2007				



DUAL SPEED

		Code	PWRC1M5i	PWRC2M5i	PWRC3M5i	PWRC5M5i
HOIST	Capacity	Lb	2.200	4.400	6.600	11.000
	Lifting Height	Ft	20 ft / 6 m	17.7 - 5.9	8.8 - 2.9	5.9 - 1.9
	Motor Power	kW	1.5 kW	3 kW	3kW	3kW
	Voltage	V	220~240/380/440~480V 50/60Hz 3 Phase			
	Motor Speed	RPM	2.880 / 960			
	Insulation Grade	Grade	F			
CHAIN	Chain Size	mm	7.1 x 21	10 x 30	11.2 x 34	
	Control		Pendant Control and Optional Wireless			
	Control Volatge		24V			
	Chain Lenght	Ft	20 ft / 6 m			30 ft / 9 m
GENERAL	Operation Temperature	F	-4 ~ 104° F / -20 ~ 40° C			
	Operating Humidity	%	<85%			
	Noise Level	dB	81			
	Control Voltage	V	24			
	Weight (*)	lb	220	385	443	544
	Dutty Class	FEM/ISO	H3/M4/1Am/Class C			
Standards		ASME B30.16 / ASMEB30.17 / ANSIZ535.4 2007				

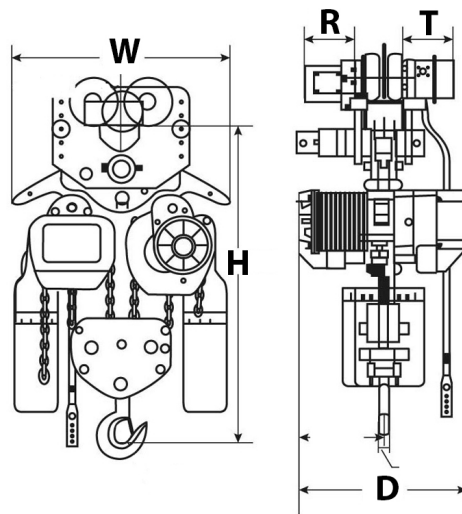
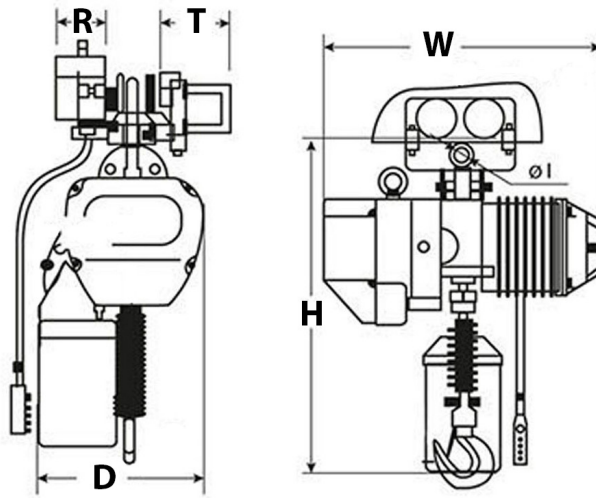

- T. Trolley Motor Width
- H. Trolley minimum Headroom
- W. Width
- R. Trolley
- D. Depth

Dimensions

Model		PWRC05M5	PWRC1M5	PWRC2M5	PWRC3M5	PWRC5M5	PWRC10M5
T	in	6.14	6.14	6.14	6.14	6.14	6.14
H		16	17	26	26	34	41
W		20	24	30	30	30	32
R		8	8	8	8	8	8
D		14	13	18	18	22	36

Model		PWRC05M5i	PWRC1M5i	PWRC2M5i	PWRC3M5i	PWRC5M5i	PWRC10M5i
T	in	6.14	6.14	6.14	6.14	6.14	6.14
H		16	17	26	26	34	41
W		20	24	30	30	30	32
R		8	8	8	8	8	8
D		14	13	18	18	22	36

SERVICE	> Load	>Time	Maintenance (Months)
NORMAL	<65%	< 25%	6~ 12
HEAVY	<65%	>25%3	3 ~ 6
SEVERE	Abnormal conditions Enviromental, geographical and/or riskY <100% <Duty Cicle Limit		1 ~ 3

WARRANTY

3 Years / Certification valid for 1 year
 10 Years parts and service avaliability

Index

PROWINCH® DISCLAIMER.....	8
SAFETY BULLETIN.....	9
SAFETY PRECAUTIONS.....	13
Mandatory Use Of.....	13
Safety Installation.....	14
Safety Operation.....	15
General Environmental Precautions.....	18
Hanging Pendant Control.....	19
SPECIFICATIONS.....	20
Advantages.....	22
Specifications chart.....	23
Selection of engines for lifting.....	25
Oil and lubricant recommendations.....	26
Inspection and maintenance.....	27
Installation.....	31
Unpacking.....	32
Chain bag assembly.....	33
Models with trolley installation.....	34
Operation.....	34
Handling Precautions.....	35
Electrical and voltage selection.....	36
Warranty.....	49
WIRING DIAGRAM	50
Conventional hoist (PWR-PWRC).....	50-53
TROUBLESHOOTING.....	54
Troubleshooting.....	54-67
PART LIST.....	68
Chain Hoist.....	68
Trolley.....	70
Electric Chain.....	73
PWR.....	78
Technical parameters.....	78 - 81
PWRC.....	82
Technical parameters.....	82 - 85
PWRM5.....	86
Technical parameters.....	86 - 89
PWRCM5.....	90
Technical parameters.....	90 - 93

Ayers USA Cranes
ayersusa.com

26111 US-90, Robertsdale,
AL 36567
251-929-1773
service@ayersusa.com

MIAMI, FL
PROWINCH LLC
www.prowinch.com

2901 NW 21st Terrace
Miami, FL 33142
United States
+1 (800) 971-8061

Fortis Alloy Mexico S.a. De C.v
Www.prowinch.mx

Fortis Alloy Mexico, S.A. de C.V. Vicente
Guerrero No. 403 Col. San Miguel,
Apodaca, Nuevo Leon,
Mexico C.P. 66649
+52 (81) 8244-1351

**Provedora Industrial
Y Tecnica, S.a. De C.v.**
Www.prointe.com.sv

Av. Alberto Masferrer Sur, Col.
Campestre No. 211
San Salvador, El Salvador
2264-1100

Guatemala

7a Avenida 1-22 Zona 13,
Pamplona, Ciudad de
Guatemala
+502 2381-8383
ever.mendez@contecindustrial.com

Lima, Peru

www.prowinch.pe
Urb. San Antonio de Carapongo.
Calle 1. Lurigancho - Lima
Phone: +51 935402797
info@prowinch.pe

Lima, Peru

www.prowinch.pe
Av Mansiche 1586, Trujillo,
La Libertad, Peru
51 44 618700
ventas@dezajacobs.com
www.dezajacobs.com

Prowinch Colombia Sas
www.prowinch.co

Cl. 163a #20-28,
Bogotá Colombia
(+57) 1 7034035

Equipos De Izaje
Prowinch Chile Spa
Www.prowinch.cl

Parque Riesco 3407, Recoleta,
Región Metropolitana, Chile
+56-2-26218989